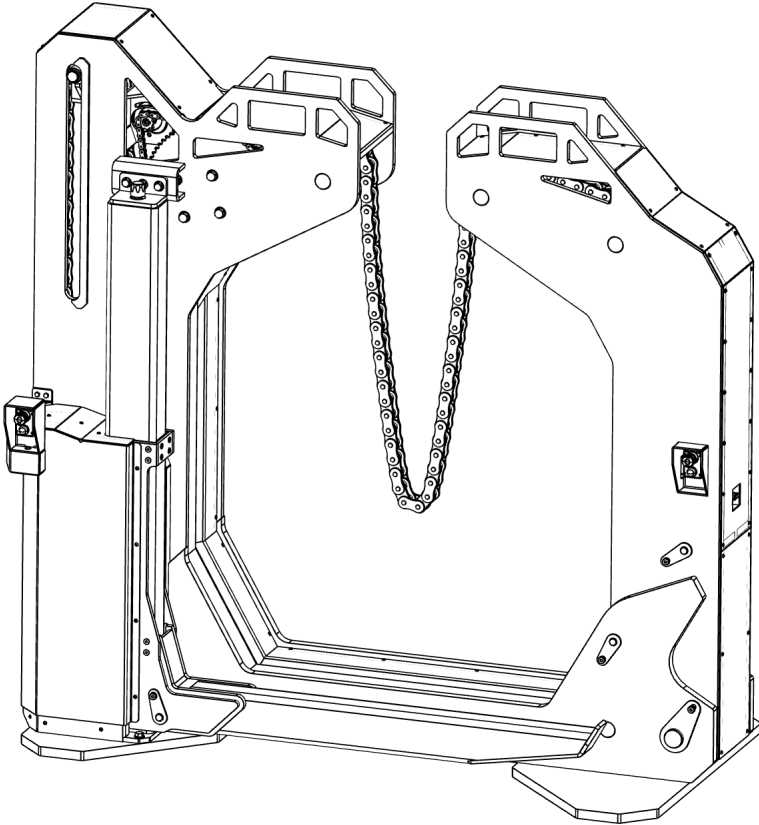


InnovaTech Beam Champ

EQUIPMENT SAFETY, OPERATION, AND MAINTENANCE



Beam Champ | IBC-360-25

INNOVATECH, LLC | HC 65 PO BOX 218 | KANARRAVILLE, UT 84742

Contents

Overview _____	1	Lubrication _____	16
Operator Qualifications _____	2	Filter Maintenance _____	16
Personal Protection Equipment (PPE) _____	2	Replacement Parts _____	17
Lockout/Tagout (LOTO) _____	2	Service Life _____	17
Emergency Stop (E-Stop) _____	2	Replacement Manuals, Decals _____	17
E-Stop Light Patterns _____	3	Subsystem Equipment Manuals _____	17
E-Stop Alarm _____	3	Model/Serial _____	17
Supplementary Documents _____	3		
Safety Markers _____	3		
Hazards _____	4		
Job Hazard Analysis (JHA) _____	4		
Pre-Operation Inspection _____	4		
Daily Checklist: _____	4		
Modifications _____	4		
Specifications _____	7		
Dimensions, Weight and Capacity _____	7		
Power Supply _____	7		
Hoisting & Relocating _____	8		
Powering On _____	8		
Powering Off _____	8		
Initialization _____	8		
Connection _____	8		
Disconnection _____	8		
Controls _____	9		
Single Unit Keypad _____	9		
System Wireless Remote _____	10		
General Operating Procedures _____	11		
Operation Alarms _____	13		
Unit Alarm Diagram _____	13		
System Alarm Diagram _____	14		
Support Arm _____	15		
Synchronize _____	15		
Maintenance Access _____	16		

Document Info

This document contains subject matter to which InnovaTech, LLC, has proprietary rights. Recipients of this document shall not duplicate, use, or disclose information contained herein, in whole or in part, for any use other than the purpose for which this manual was provided.

InnovaTech, LLC, believes the information described in this manual is accurate and reliable. From time to time, design improvements will be made to the InnovaTech Beam Champ. Photographs, text, and sketches within the body of this manual may not exactly represent your equipment. In general, this manual contains the most up-to-date information available. However, InnovaTech, LLC, cannot accept any responsibility, financial or otherwise, for any consequences arising out of the use of this material. The information contained herein is subject to change, and revisions may be issued to advise of such changes or additions.

InnovaTech, LLC, strives to continually improve their user documentation. If you have any questions or concerns about the content of this service and maintenance guide, we want to hear from you. Please e-mail us at support@innovatechservice.com or contact us by mail at:

INNOVATECH, LLC
TECHNICAL PUBLICATIONS
HC 65 PO BOX 218
KANARRAVILLE, UT, USA 84742

InnovaTech, LLC, is continually improving their equipment to bring you the latest in building system technology. For that reason, your InnovaTech Beam Champ may differ slightly from what is described in this document. If you have any questions, please contact us at support@innovatechservice.com.

The InnovaTech, LLC, Panelization System is under US PATENT PENDING protection.

©2021 InnovaTech, LLC. All Rights Reserved.

InnovaTech Beam Champ System

Overview

The InnovaTech Beam Champ is an industrial equipment solution designed to enhance workplace safety and efficiency in steel fabrication shops where steel beams are being fabricated. The InnovaTech Beam Champ System is designed to include two or more Beam Champ units that work in sync with each other to rotate a single beam. The beam is cradled on chain, and rotated within the “throat” of the Beam Champ as the chain moves.

While there are many beam rotation solutions on the market, the InnovaTech Beam Champ is designed to eliminate many problems experienced in the use of other branded beam rotators. These improvements include the Vertical Jaw Arm which opens the Beam Champ for the placement or removal of a beam (see Fig. 2), as well as the Support Arm which holds the beam in place while workers weld or configure the beam.

Throughout this manual, the use of the terms “set” or “system” is in reference to multiple Beam Champs connected to each other (see Fig. 3). Use of the terms “local” or “unit” is in reference to a single Beam Champ.

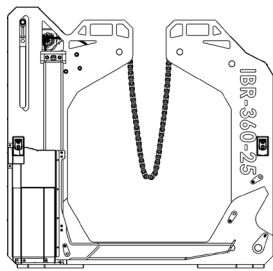


Fig. 1: Vertical Jaw Closed

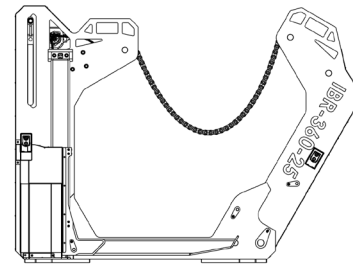


Fig. 2: Vertical Jaw Open

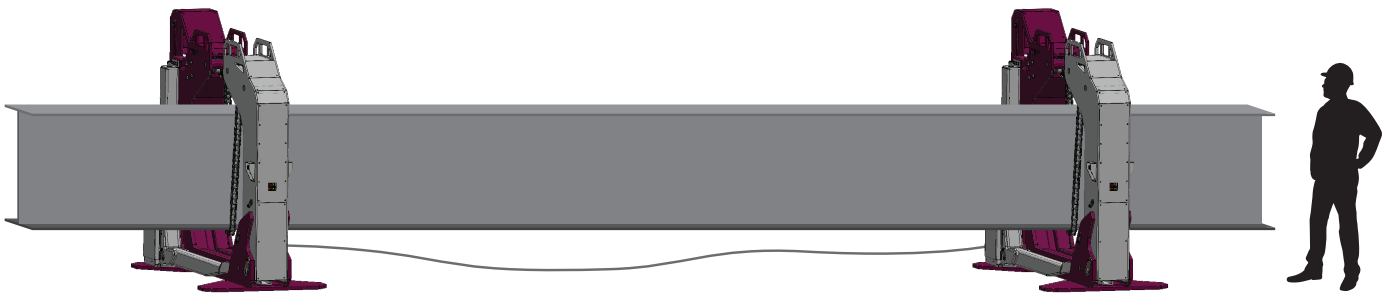


Fig. 3: InnovaTech Beam Champs operate in sets of two or more

Safety

Operator Qualifications

DO NOT OPERATE the Beam Champ unless you have been trained and qualified to do so. Operator must follow ALL appropriate safety regulations. Operator trainees must remain under observation and supervision of an experienced operator. Operators must be in good physical and mental condition, with appropriate reflexes, reaction time, vision, depth perception, and hearing. Beam Champ operator(s) must be 18 years of age or older.

Operators must read this operators' manual completely and carefully to understand the safety instructions and the operation of controls. A brief description of controls, indicators, and instruments are provided as a convenience for the operator. These descriptions DO NOT provide complete operation instructions, and should not be substituted for proper operator training and common sense.

Operators must understand and comply with all CAUTION, WARNING, and DANGER notices. (Refer to "Safety Markers" on page 3 for detailed information on safety marker definitions.)

Operators must have the required training, skills, and tools to perform installation, operation, maintenance, or repair procedures properly and safely. The operator is responsible to operate and maintain the Beam Champ according to manufacturer's instructions.

If any doubt or question arises about the correct or safe methods for operating the Beam Champ, operators must not proceed until obtaining qualified assistance.

Beam Champ training must be approved by InnovaTech. Training must include reading and understanding this operation and safety manual, safety labels, employer work rules, and applicable government regulations. Consult a supervisor to explain any unclear instructions and warnings. Consult InnovaTech to replace lost manuals.

Personal Protection Equipment (PPE)

PPE should be utilized according to the type of work and environmental conditions a worker is exposed to. These items may include reflective vests, safety glasses, welding PPE, safety-toe footwear, gloves, helmets, goggles, face shields, and hearing protection.

Lockout

In accordance with Occupational Safety and Health Administration (OSHA) regulations, Lockout must be used in any cases where Beam Champ is unsafe to operate or if it is being serviced or repaired. Lock should be placed at the Lockout points on machine (see below), following OSHA standard Lockout procedures. Under no circumstances should operator use the Beam Champ if deemed unsafe.

Lockout/Tagout Procedures

1. Turn power switch to "OFF" position, apply lock. (see "Nomenclature" on page 6)
2. Disconnect from power supply.
3. Apply lockable enclosure over plug; apply lock.

Emergency Stop (E-Stop)

There are four (4) emergency stops on each Beam Champ, one near each corner of the machine. If any one of the E-Stops are depressed, the entire Beam Champ or set of Beam Champs will stop immediately.

E-Stop Light Patterns

Each emergency stop module includes a light indicator. The light patterns below are applicable per unit but not per set. This feature helps the operator easily identify which E-Stop has been pressed.

Light Color	Description
Green	No E-Stops depressed
Red	Target E-Stop has been depressed
Light Off	Target E-Stop is not active, but one or more E-Stops have been depressed

E-Stop Alarm

Chirping sound will be heard (once every 2 seconds) when any Emergency Stop has been pressed or if connection is lost between units in a set.

For Operational Alarms, see “Operation Alarms” on page 12.

Supplementary Documents

InnovaTech also provides checklist forms for safety, maintenance, and operator certification. If forms are not available to you, contact an InnovaTech representative at support@innovatechservice.com.

Safety Markers



This is the safety alert symbol. It is used to alert you to the potential personal injury hazards. Obey all safety messages that follow this symbol to avoid possible injury or death.

CAUTION

Indicates a potentially hazardous situation. If not avoided, may result in minor or moderate injury. It may also alert against unsafe practices. This decal will have a yellow background.

WARNING

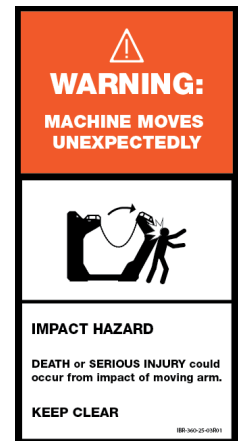
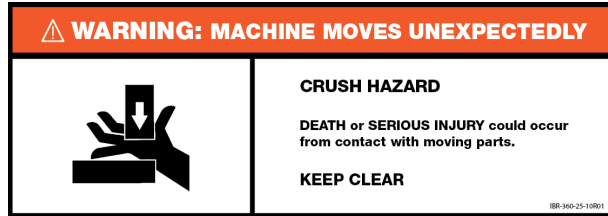
Indicates a potentially hazardous situation. If not avoided could result in serious injury or death. This decal will have an orange background.

DANGER

Indicates an imminently hazardous situation. If not avoided, will result in serious injury or death. This decal will have a red background.

Hazards

Read and understand all CAUTION, WARNING, DANGER, and operating instructions on the machine and in this manual. The Beam Champ should only be used as intended. Do not use Beam Champ for horseplay.



Job Hazard Analysis (JHA)

Although the Beam Champ system is designed to enhance safety, it remains important for workers to carefully analyze the work to be performed. Identifying work methods, planning actions, communicating clearly, and maintaining a positive attitude, teamwork, and compliance with worksite authority all contribute to a safe workplace.

If the Beam Champ is to be used, the use of the Beam Champ system should be included in your company's Job Hazard Analysis documentation. Topics to consider should include the use of overhead cranes and number of workers in Beam Champ work area. See following page for sample JHA form (employers are authorized to copy form as needed).

Pre-Operation Inspection

Walk around the ENTIRE Beam Champ while visually performing the pre-operation inspection:

- Check that "Do Not Operate" tags have not been placed on the Beam Champ.
- Check that Operation and Safety Manual is in the protective case and legible.
- Check for loose or missing bolts and nuts.
- Check for cracked or bent members.

Daily Checklist:

- Check hydraulic oil level sight glass. All axis must be in the fully retracted position.

Modifications

⚠ WARNING

Modifications to the Beam Champ or attachments could affect capacity and/or stability which could result in death or serious injury. DO NOT make modifications to the Beam Champ or attachments without prior written approval from Innovatech Products. Where such authorization is granted, capacity, operation, and maintenance instruction plates, tags, or labels shall be changed accordingly. Unauthorized modifications or alterations will void the warranty.

- DO NOT modify, disable, or bypass any safety devices.
- DO NOT burn or drill holes in attachments.

Job Hazard Analysis (JHA) Form

JHA NUMBER	JHA NAME		MACHINE ID
NAME OF FACILITY	DEPARTMENT		
NAME OF PERSON(S) PREPARING JHA (I.E.: MACHINE OPERATOR, SAFETY COMMITTEE MEMBER)			
NAME OF PERSON(S) APPROVING JHA (I.E.: SAFETY OFFICER, PLANT MANAGER)			
DATE COMPLETED	DATE REVISED	DATE REVIEWED	POSITION/TITLE OF PERSON WHO PERFORMS JOB
JOB STEP DESCRIPTION			
POTENTIAL HAZARD DESCRIPTION			
PROCEDURE TO BE FOLLOWED			
SAFETY PRECAUTIONS (IF PROCEDURE DOES NOT FULLY CONTROL RISKS)			
COMMENTS			

Each JHA must be site specific. Include all workers in the development of this JSA.

NEXT REVIEW DATE (<5 yrs): _____

Nomenclature

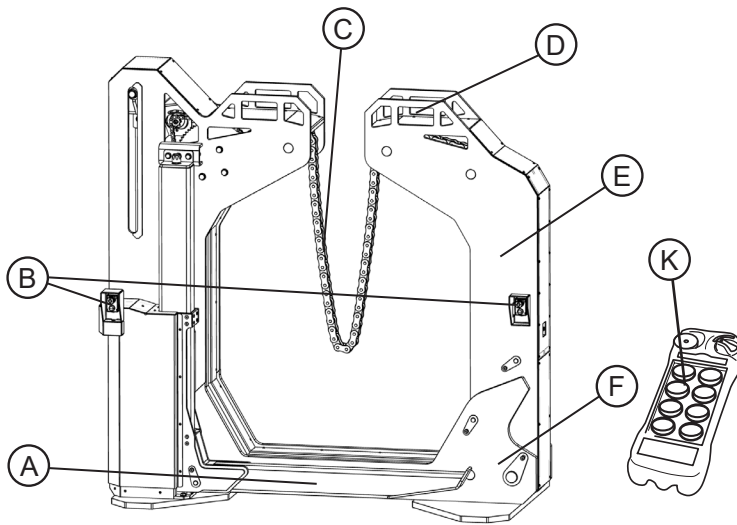


Fig. 4: Side 1

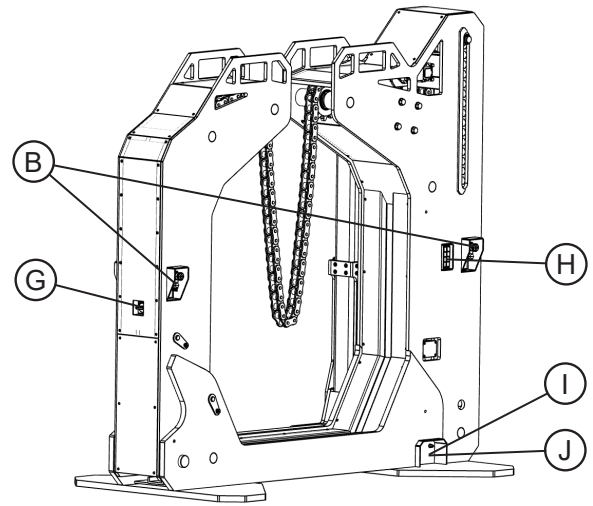
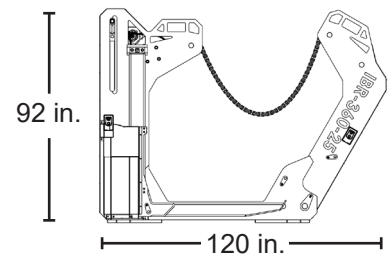
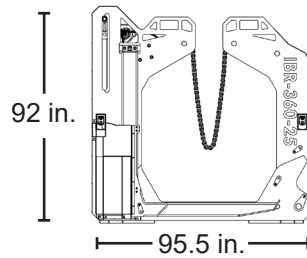
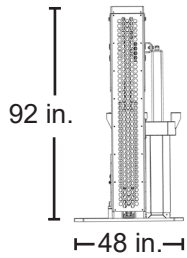


Fig. 5: Side 2

- A. Support Arm** - supports weight of beam while beam undergoes welding or other process
- B. Emergency Stop** - stops motion of all Beam Champs in set
- C. Rotation Chain** - supports the weight of the beam during rotation and rotates the beam
- D. Lift Pockets** - provides lift point for moving and positioning
- E. Vertical Jaw Arm** - opens “throat” of Beam Champ for placement or removal of beam
- F. Vertical Jaw Arm Fulcrum** - provides pivot point on which Jaw Arm swings
- G. Power Switch / Lockout Point** - provides power on/off switch and lockout point
- H. Unit Keypad** - controls single Beam Champ unit
- I. Communication Link Connection** - connects to one or more Beam Champs to create a set
- J. Power Cord** - connects to power supply (25 ft mounted cord)
- K. Wireless System Remote Keypad** - controls set of Beam Champs simultaneously

Specifications

Dimensions, Weight and Capacity



Description	Jaw Closed	Jaw Open
Length	96.5 in	120 in
Height	92 in	92 in
Width	48 in	48 in
Net Weight	5,700 lbs	
Weight Capacity (per unit)	25,000 lbs	

Power Supply

Each Beam Champ unit must be connected to its own power supply.

Power Specifications Per Unit	NEMA L16-30 (480 V 3-phase, 30 Amp)
--------------------------------------	-------------------------------------

Setup

Hoisting & Relocating

WARNING

Unplug power supply before hoisting or relocating Beam Champ.

WARNING

Only use lift pockets located on top of Beam Champ for lifting unit. Do not use Beam Champ chain for hoisting.

Use caution when hoisting and relocating a Beam Champ. Follow all safety rules and procedures relevant to movement of machinery. Only use hoisting equipment rated to lift at least 6,000 lbs. Beam Champs in a set should be positioned such that beam center of gravity is between the two end Beam Champs.

Powering On

Plug in unit to power supply (see “Specifications” on page 7). Turn power switch to “on”.

Powering Off

Turn power switch to “off”.

Initialization

Immediately after Beam Champ is connected to power supply it will begin to initialize, updating its memory with any current connections to other Beam Champs. Thereafter, each Beam Champ is constantly (about 20 times a second) communicating its current status to all other Beam Champs within the set.

Allow 5 seconds for Beam Champs to initialize before beginning operations.

Connection

Plug communication cable from one Beam Champ unit to another (see “Nomenclature” on page 6). At time of printing this manual, a maximum of seven (7) Beam Champs can be in a set.

Disconnection

To remove a Beam Champ from a set, disconnect the communication from the unit being removed and re-initialize the remaining units as a new set. When a Beam Champ is disconnected from set, the remaining Beam Champ units will immediately activate Emergency Stop mode. Reconnecting the Beam Champ to the set will deactivate the Emergency Stop mode. In the event that reconnection does not deactivate E-Stop mode, disconnect all units from power then reconnect power.

Operation

The InnovaTech Beam Champ System is intended to include two (2) or more units connected to each other via the communication cable or radio bridge. Each Beam Champ unit has a control keypad which controls only that specific unit (excepting the beam rotation functions), while the System Remote Keypad controls the connected “set” of Beam Champs simultaneously.

Controls

On both unit keypad and system remote controls, buttons must be held depressed for the duration of motion. If there are conflicting commands from multiple sources, first command locks out all conflicting commands until button is released.

System Wireless Remote

The System Remote Keypad buttons are proportional, meaning the harder/further the button is pressed, the faster the speed of motion. All wireless remote buttons control all the Beam Champs in the set simultaneously.

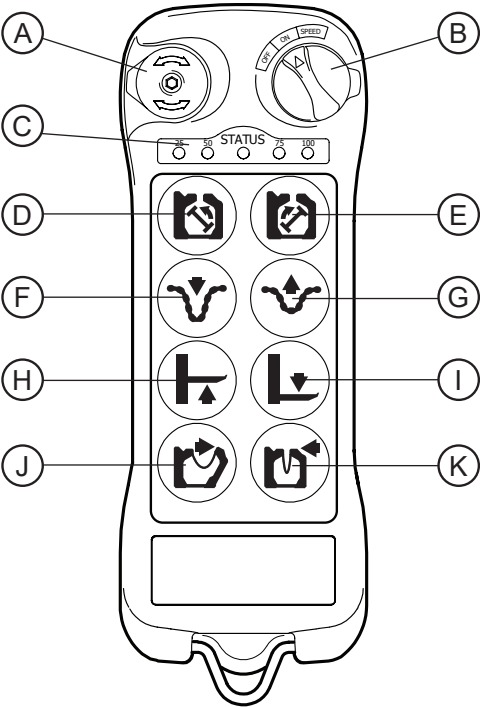
 <p>The diagram shows a vertical, handheld remote keypad. At the top left is a circular button labeled 'A'. To its right is a rotary switch labeled 'B' with 'OFF', 'ON', and 'SPEED' positions. Below these are four small circular LEDs labeled 'C'. The main control area consists of a 4x2 grid of buttons: 'D' (left arrow), 'E' (right arrow), 'F' (downward arrow), 'G' (upward arrow), 'H' (upward arrow with rightward arrow), 'I' (downward arrow with rightward arrow), 'J' (curved arrow pointing up and right), and 'K' (curved arrow pointing down and right). At the bottom is a rectangular display area.</p>	<p>A. Stop Button - function same as E-Stop, only when wireless remote is powered on and connected</p>
	<p>B. Keyswitch - multi-function Off/On/Speed switch</p>
	<p>C. Status LED Indicators - Power and speed indicators</p>
	<p>D. Rotate - beam away from Vertical Jaw Arm</p>
	<p>E. Rotate - beam toward Vertical Jaw Arm</p>
	<p>F. In - Chain slack decrease</p>
	<p>G. Out - Chain slack increase</p>
	<p>H. Up - Support Arm raise</p>
	<p>I. Down - Support Arm lower</p>
	<p>J. Open - Vertical Jaw open</p>
	<p>K. Close - Vertical Jaw close</p>

Fig. 6: System Remote Keypad Nomenclature

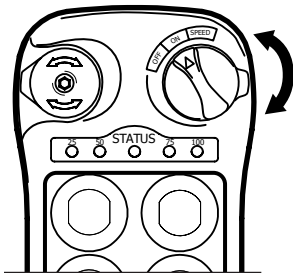


Fig. 7: Wireless Remote Keypad "On"

1. Turn on transmitter power by rotating keyswitch to the "On" position
2. After turning on transmitter power, check the Status LED on the transmitter handset for any sign of system irregularities. If the system is normal the Status LED will light up green for two (2) seconds, then slowly flash green.

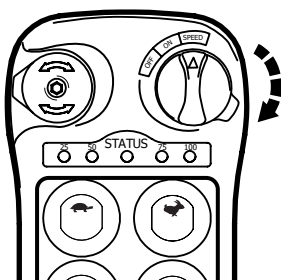


Fig. 8: Wireless Remote Keypad "Speed"

3. Now press any push button on the transmitter handset to operate the Beam Champ. When a button is pressed, the Status LED will flash orange with a variable speed dependent on how far the button is pressed. The further a button is pressed, the faster the LED will flash. When no buttons are pressed, the Status LED will slowly blink green.

The Remote Keypad has four (4) speed settings which are percentages of the system maximum speed: 25%, 50%, 75%, and 100%. These settings control the maximum speed value of the buttons when fully depressed. (For example, if the speed setting is set to 25%, the motion of the machine will be controlled by how far the button is pressed, with variable speed from 1-25%).

4. To adjust the Remote Keypad speed, move keyswitch to "Speed" position. Hold keyswitch in position while pressing top left to decrease, or top right to increase. LED light will indicate which speed setting is active.
5. After a period of inactivity (push button not pressed), the remote must cycle power before turning on again. Turn keyswitch to "Off" position and follow instructions on paragraphs 1 and 2.

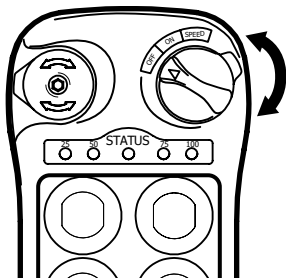
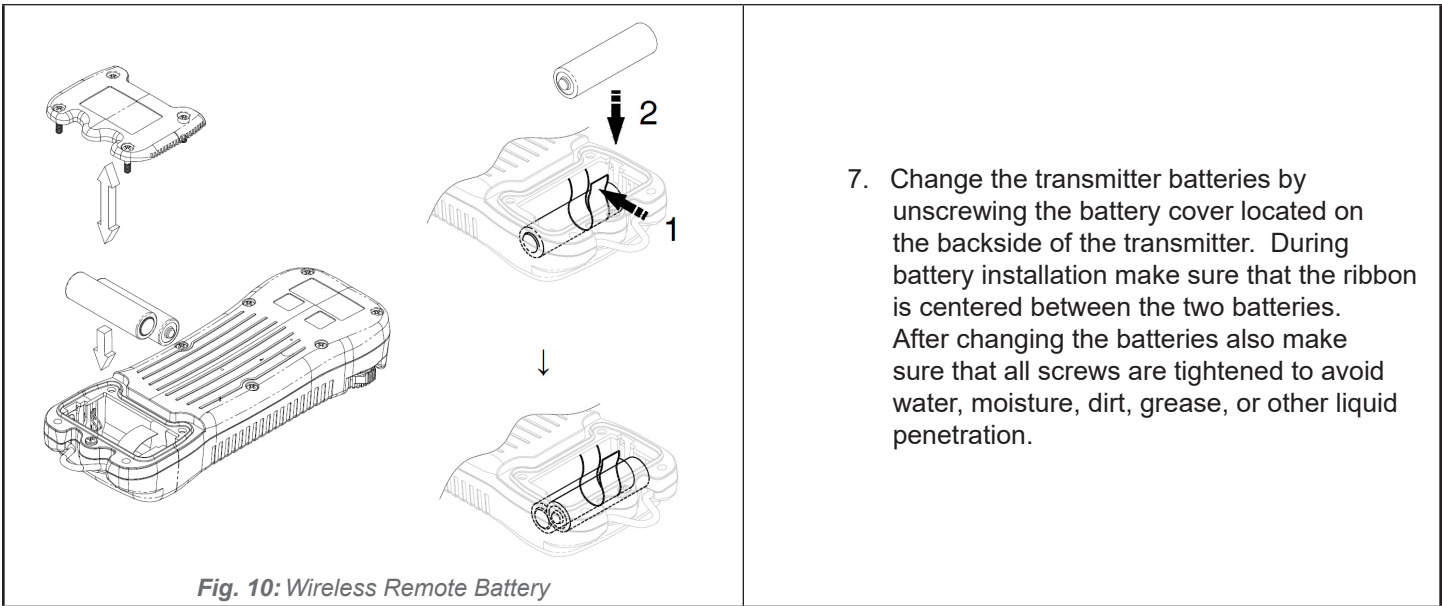


Fig. 9: Wireless Remote Keypad "Off"

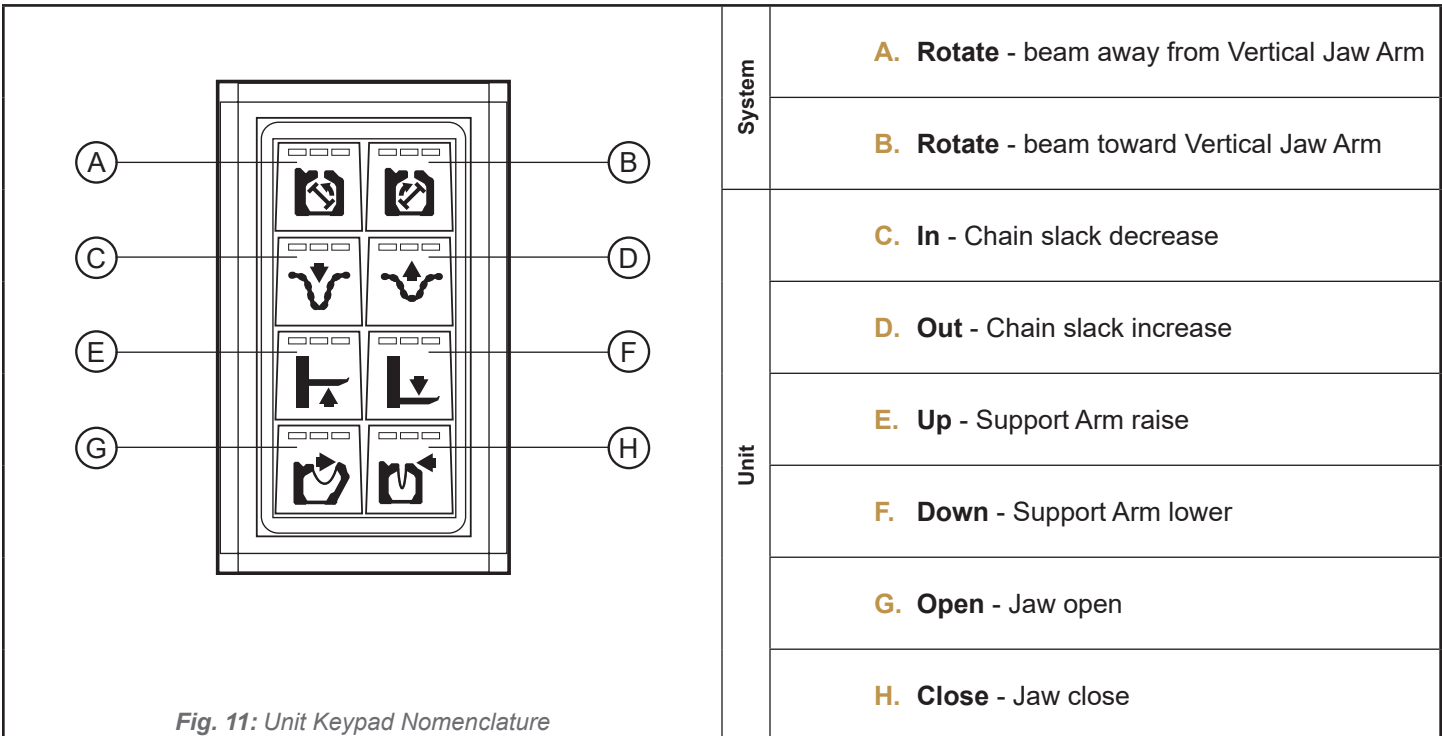
6. Turn off the transmitter power by rotating the power key counter-clockwise to the "Off" position (Status LED becomes a solid red for 4 seconds). This will disconnect the transmitter from the receiver.



Single Unit Keypad

Unit keypads do not have proportional buttons. All commands from the Unit Keypads run at speed 100%, regardless of what speed the System Remote Control is set to. LEDs on unit keypad buttons light up when function is active.

All functions on unit keypad, except Forward and Reverse, only control the single unit.

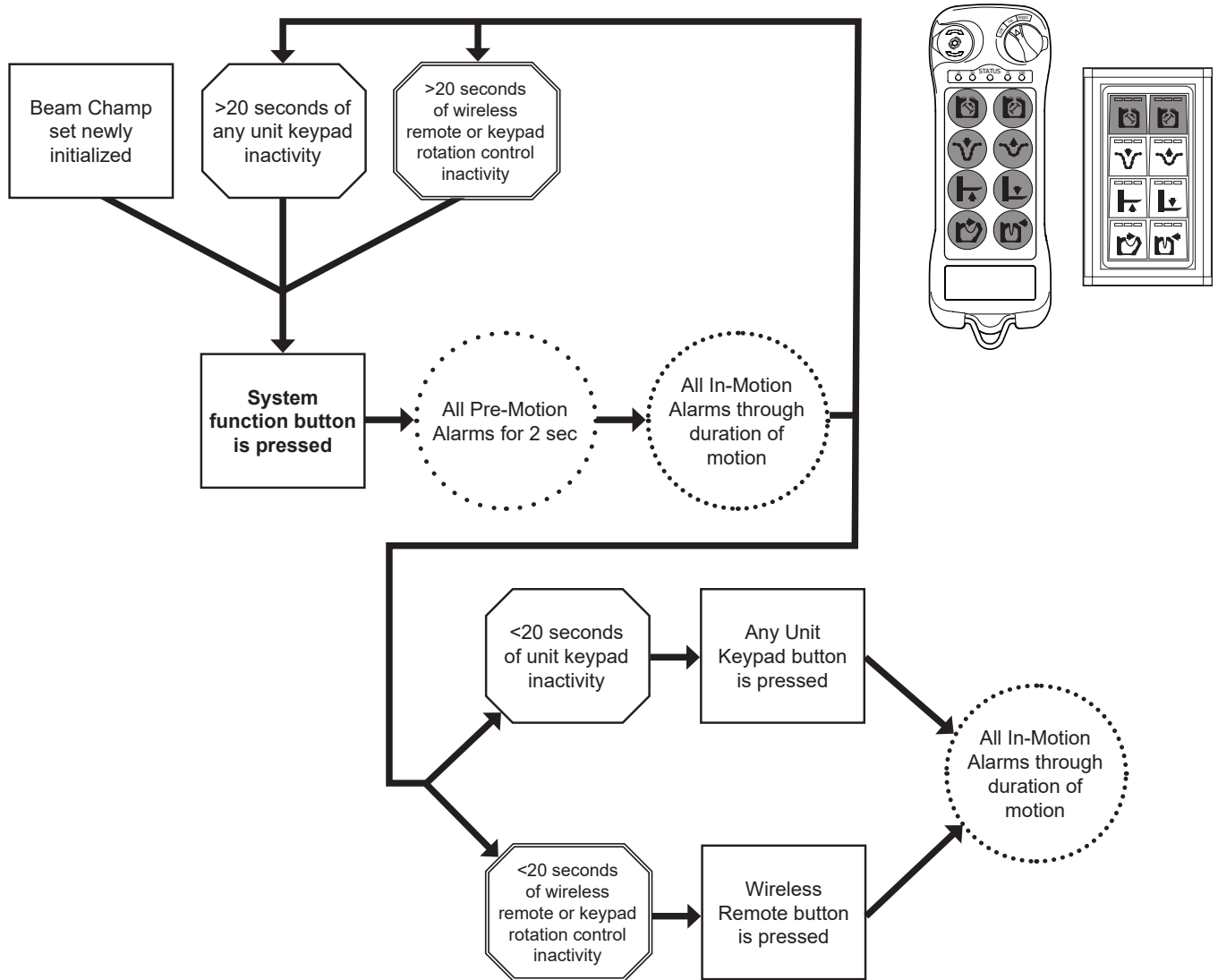


Operation Alarms

For safety purposes, Beam Champs have an operation alarm system per unit and per set, which become active while Beam Champ(s) are in motion. See following diagrams for alarm logic.

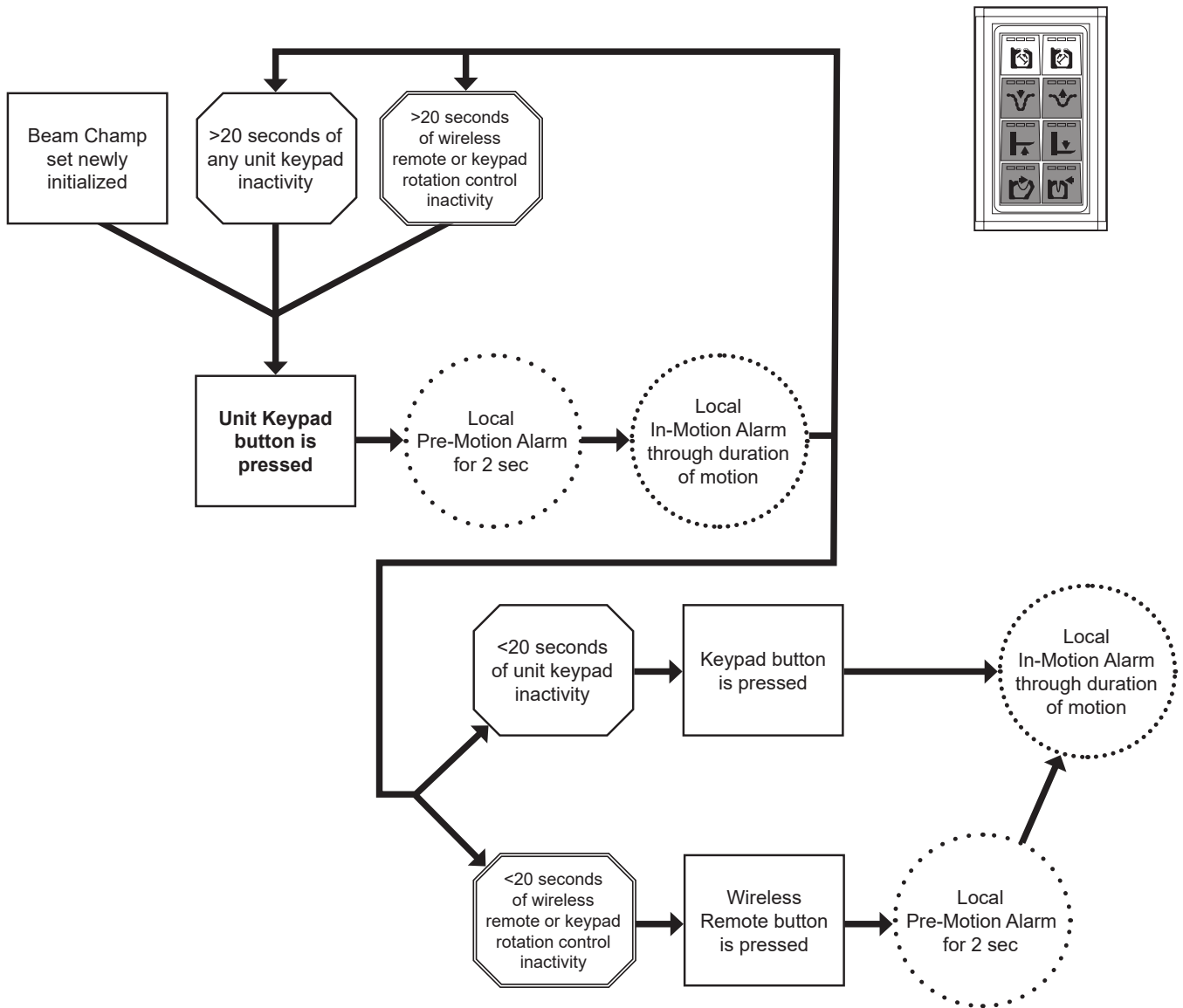
System Alarm Diagram

The wireless remote keypad and system functions on the unit keypad initiate the system alarm sequences.

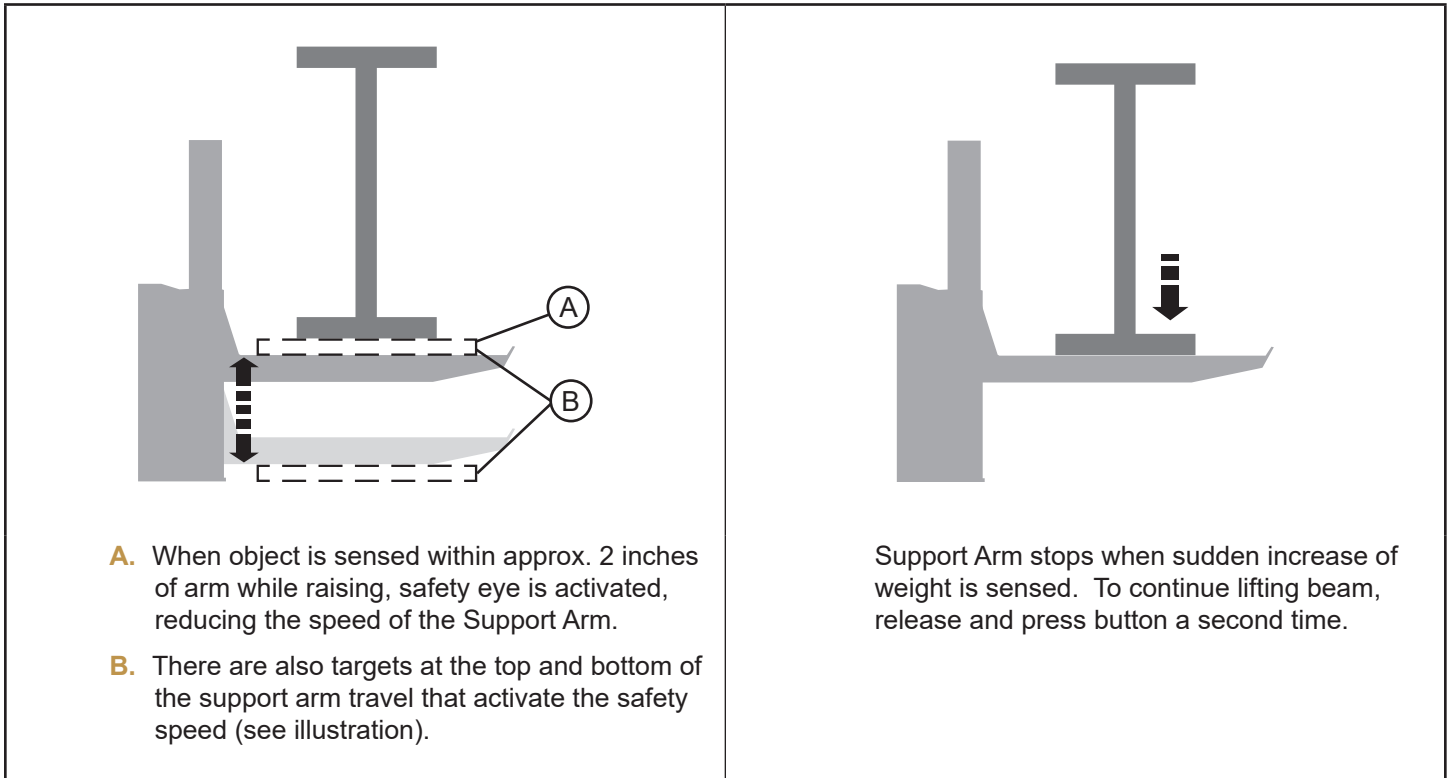


Unit Alarm Diagram

Each unit uses its own timer.



Support Arm



Synchronize

To synchronize the axis positions of a set of Beam Champs, press and hold button on system wireless remote for each function: jaw, support arm, and chain slack, until the axis of all units have reached the maximum position.

Maintenance

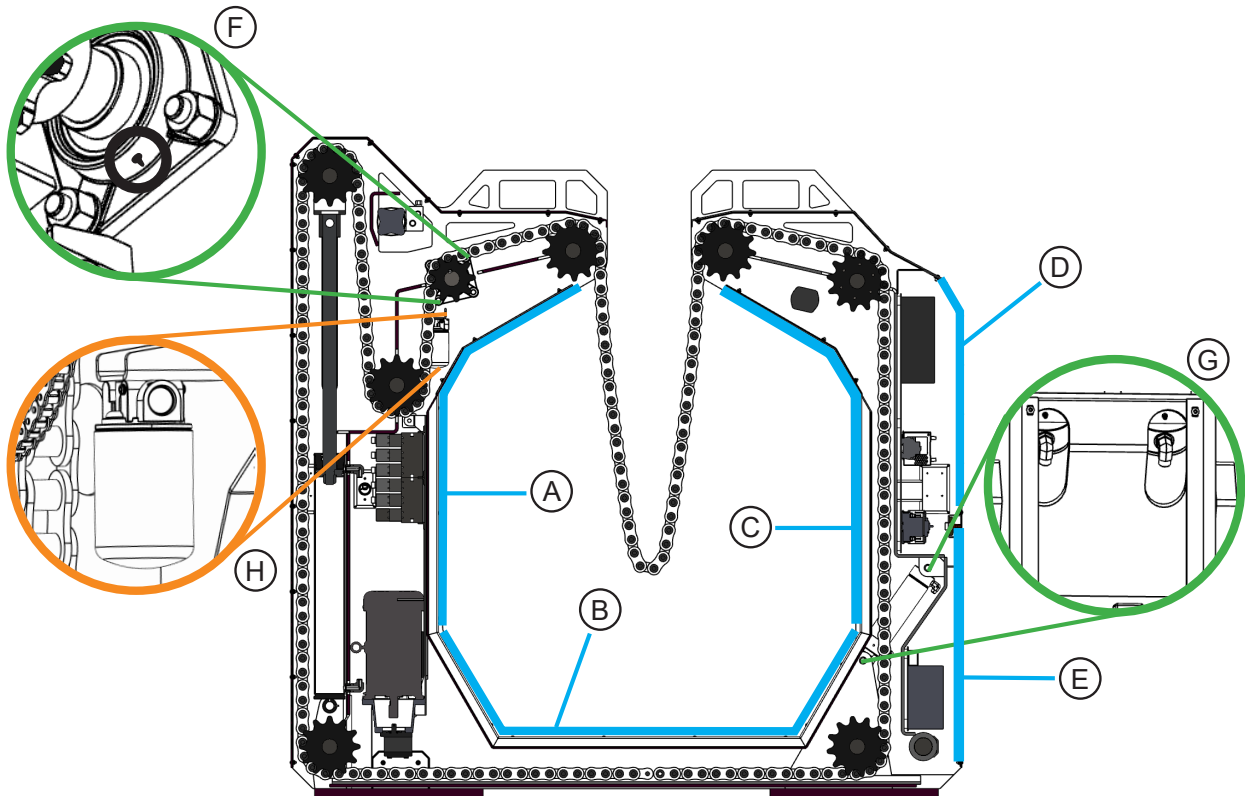
The Beam Champ is completely hydraulic driven.

⚠ WARNING

Always follow lockout procedures when performing maintenance or repairing equipment. See “Lockout” on page 2.

⚠ WARNING

Follow electrical safety protocols when accessing High Voltage area (C).



Access Panels

A. Hydraulic Valve - hydraulic valve and lube point access
B. Throat Bottom - auxiliary maintenance access
C. Jaw Arm Inside - auxiliary hydraulic cylinder access
D. High Voltage Electrical - High Voltage (480 V) electrical components
E. Low Voltage Electrical - Low Voltage (24 V) electrical components and hydraulic lubrication points

Lubrication Maintenance

Location	Interval
F. Grease Flange Bearings - Access via throat cover (A). Apply EP grease to both sides of sprocket (2 zerks).	every 6 months
G. Hydraulic Cylinders - Access via hydraulic cover (D). Apply EP grease to both ends of both cylinders (4 zerks)	yearly

Hydraulic Maintenance

H. Hydraulic Oil Filter - Access via hydraulic valve cover (A) Hydraulic Oil -	every 6 months
------------------------------------------------------------------------------------------	----------------

Replacement Parts

Contact InnovaTech for information regarding replacement parts.

Service Life

InnovaTech Products and Services are constantly being improved for serviceability and durability. If any portion of the equipment is deemed unsafe, or in poor repair, appropriate procedures should be initiated for repair or replacement. If onsite repairs are necessary, appropriate Lock-Out/Tag-Out procedures must be initiated. Beam Champ should not be operated for any length of time if deemed unsafe.

Replacement Manuals, Decals

Replacement manuals and decals for the Beam Champ can be obtained by contacting us by phone, mail, or email. Please note the manual part number located on the bottom of each page, or decal number located on the decal, when making requests.

Subsystem Equipment Manuals

The manuals to each of the subsystem equipment specified in this document can be found on our website or from a link to the manufacturers website. Manufacturer documentation may be available for download via these websites. This list may be incomplete. Contact an InnovaTech representative for information on compatible subsystem equipment.

FlexPro Remote Transmitter - www.magnetek.com

Model/Serial

When contacting our service representatives, please have the Beam Champ serial number available. The serial tags are located below the emergency stops opposite the Vertical Jaw Arm.

Contact Us

INNOVATECH, LLC

HC 65 PO BOX 218 | KANARRAVILLE, UT 84742

Email support@innovatechservice.com

