

MezzMaster 200

ATTACHMENT USE & SAFETY

MZM-200

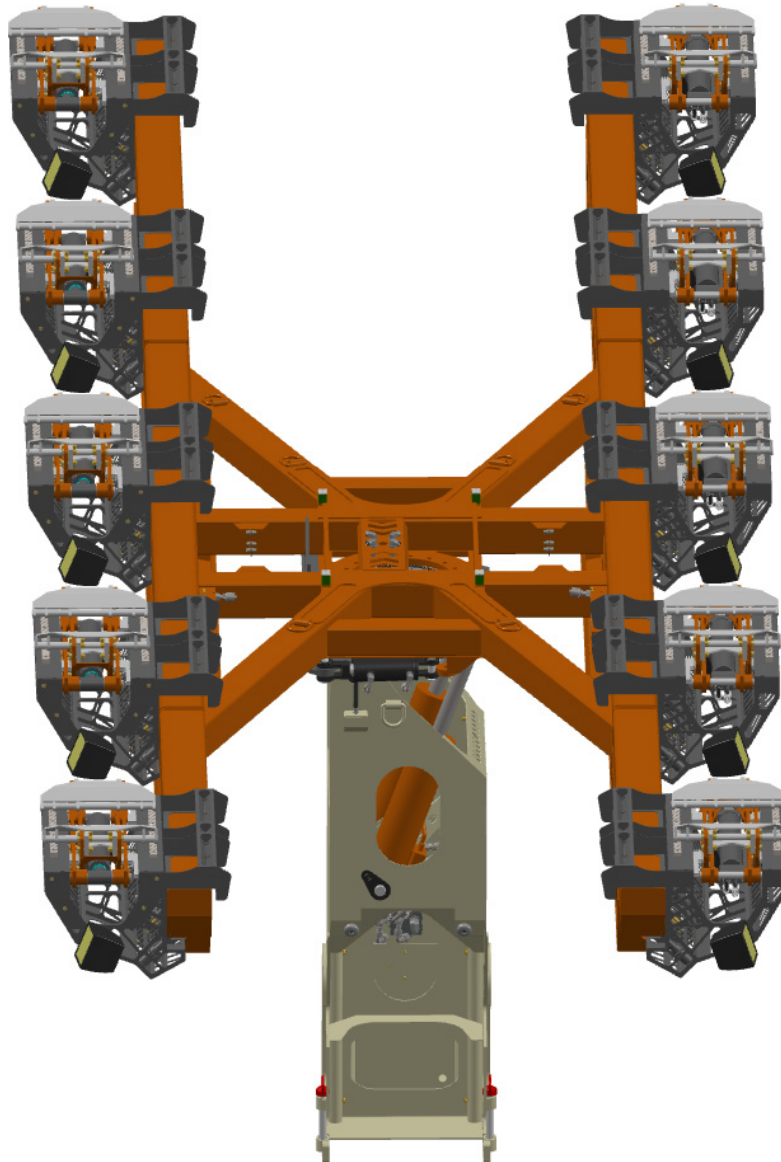

Innovatech Manufacturing
4360 N WECCO Rd
Cedar City, UT 84721
<https://innova.tech>

MZM-200

MZM200-OSMNLV01R00

Document Information

Revision Log

Produced by: InnovaTech Manufacturing
Product: MezzMaster 200 Attachment Use and Safety Manual
Manual Product Code: MZM200-OSMNLV01R00
Version: 1st Version
Production Date: February 15, 2024

This manual is intended as a basic source of information, providing general information as well as specific warnings and instructions on the safe use and maintenance of InnovaTech Manufacturing's MezzMaster 200.

Safety is paramount. InnovaTech Manufacturing presents this information as a reference and guide only, not an all-encompassing "rule-book" on safety. It is the purchaser's and user's responsibility to identify specific safety hazards and determine proper procedures to prevent those hazards from inflicting injury.

All information is based on the latest product information at the time of publication. However, there may be design improvements from time to time so that photographs, text, and sketches may not exactly match your product. InnovaTech Manufacturing's responsibility, financial or otherwise, for any consequences arising out of the use of this manual or its products is limited by our product warranty. The information contained herein is subject to change, and revisions may be issued to advise of such changes. InnovaTech reserves the right to make product changes at any time without obligation.

This document contains subject matter to which InnovaTech Manufacturing has proprietary rights. Recipients shall not duplicate, use, or disclose information contained herein, in whole or in part, for any use other than for product use and for training personnel on safe use and maintenance.

If you have any questions or concerns about the content of this Product Use and Safety Manual or, if you would like to request updated information, please contact us:

<https://innova.tech>

support@innova.tech

INNOVATECH MANUFACTURING
TECHNICAL PUBLICATIONS
4360 N WECCO RD
CEDAR CITY, UT, USA 84721

Table of Contents

Document Information	II
Revision Log	II
1. Safety	2
1.1 Safety Considerations	2
A. Machine Voltage	2
B. Power Lines	2
1.3 Moving Parts	3
1.4 Clamp Assembly Bolts	3
1.5 Hydraulics	3
1.6 Safety Sensors	3
1.7 Hoisting/Lifting	3
1.8 Wind and Weather	3
1.9 Labels and Decals	3
2. Overview	4
Purpose	4
Structure	4
Nomenclatures	4
A. Clamp Assembly	4
B. MezzMaster	5
3. Operation	6
3.1 Operation Safety	6
3.2 Telehandler Up-Fit Kit	6
3.3 Set-up	6
3.4 Inspection	6
Per Shift:	6
3.5 MezzMaster Controls	7
A. Telehandler 2450 Joystick	7
LED Light Patterns	7
MezzMaster Mode	7
Swing Carriage Mode	7
B. XTreme XR-50100 Joystick (Trackzilla)	8
Trackzilla Mode	8
Swing Carriage Mode	8
3.6 Operating MezzMaster	9
3.7 Transport, Storage	9
4. Maintenance	9
per shift:	9
6 Month Inspection	9
MezzMaster must be inspected:	9
5. Specifications	10
General	10
Telehandler Compatibility:	10
Dimensions	10
Capacity	10
Maneuverability	10
Systems	10
Electrical System	10
Hydraulic System	10
Appendix: Labels and Decals	11

Document Information

1. Safety

2. Overview

3. Operation

4. Maintenance

5. Specifications









Appendix

1. Safety

Before using the MezzMaster, read this manual carefully. Follow all state and federal health laws and local regulations. **A**lways **B**e **C**areful. Because the MezzMaster is a forklift attachment, safety precautions

for using a forklift must be considered. Be familiar with the forklift manual.

Safety Alerts

Hazard Level	Signal Word	Signal Color	Signal Symbol	Signal Example	Signal Meaning
Extreme	DANGER	RED			DANGER indicates a hazardous situation which, if not avoided, WILL result in death or serious injury.
High	WARNING	ORANGE			WARNING indicates a hazardous situation which, if not avoided, COULD result in death or serious injury.
Medium	CAUTION	YELLOW			CAUTION indicates a hazardous situation which, if not avoided, MAY result in moderate injury.
Low	CAUTION	YELLOW	no symbol		CAUTION (without a symbol) indicates a hazard or practice not related to personal injury.
NA	NOTICE	BLUE	no symbol		NOTICE addresses practices not related to personal injury, but may give information for safe use.

1.1 Safety Considerations

The MezzMaster is an attachment with an electrical and hydraulic system which are powered by the functions of a telehandler. Hydraulic and electrical systems have hazards. There are also pinch and crush hazards associated with the MezzMaster. Telehandler operators managing the MezzMaster should exercise safety precautions when lifting, moving, and setting the MezzMaster.

- Ensure electrical cover is in place and closed securely.
- Lock the product and tag it out of service if electrical parts are malfunctioning.

1.2 Electrical Hazard

A. Machine Voltage

 **ELECTRIC SHOCK CAN INJURE!**

- Do not touch live electrical parts.
- Make sure power is disconnected before accessing electrical parts.

B. Power Lines

 **POWER LINES ARE DEADLY!**

- Power lines transport hundreds of thousands of volts.
- Contact with an item that is touching a power line will cause electrocution.
- Follow the MAD table.
- Be extremely cautious when working around power lines.



Minimum Safe Approach Distance (MAD)	
Voltage Range (Phase to Phase)	Minimum Safe Approach Distance
0-300V	Avoid Contact
Over 300V to 50 kV	10 feet
Over 50 kV to 200 kV	15 feet
Over 200 kV to 350 kV	20 feet
Over 350 kV to 500 kV	25 feet
Over 500 kV to 750 kV	35 feet
Over 750 kV to 1000 kV	45 feet

1.3 Moving Parts

 **MOVING PARTS ARE HAZARDOUS!**

- Keep clear of moving parts. Keep hands, hair, loose clothing, and tools away from moving parts.
- Ensure covers are in place.

1.4 Clamp Assembly Bolts

 **LOOSE BOLTS ARE A HAZARD!**

- Ensure all clamp bolts are tight.
- Loose bolts on Clamp Assembly endangers people and equipment.

1.5 Hydraulics

 **PRESSURIZED FLUID IS A HAZARD!**

- Hydraulic hoses can develop high pressure leaks.
- Hydraulic fluid under pressure can inject into the flesh even through a glove.
- Ensure hydraulic junction cover is in place

and closed tightly.

- Hydraulic fluid injection can cause serious reactions and infection.
- ***In case of hydraulic fluid injection seek medical attention at once.***

1.6 Safety Sensors

 **MALFUNCTIONING SENSORS CAN RESULT IN INJURY OR DEATH!**

- Do not bypass sensors.
- If a sensor is not working properly, lock the machine and tag it out of service until the problem is fixed.

1.7 Hoisting/Lifting

 **HOISTING/LIFTING IS HAZARDOUS!**

- Follow safety precautions while lifting.
- No one should be under the load while it is being lifted.
- Lift only from designated lift points.

1.8 Wind and Weather

 **WIND OR LIGHTENING CAN KILL!**

- Do not operate the MezzMaster during lightning or thunderstorms,
- Do not operate the MezzMaster in winds more than 35 mph.

1.9 Labels and Decals

 **MISSING INFORMATION IS A HAZARD!**

- Ensure all information labels and decals are legible.



2. Overview

Purpose

The MezzMaster 200 is a telehandler D-Carriage attachment made specifically for Xtreme's Telehandler XR-50100, also known as Trackzilla. It is designed to lift prefabricated mezzanine and roof panels from a large jig. The MezzMaster is used to carry the panel from the panel jig to the building structure. The MezzMaster has hydraulically actuated clamps to facilitate securing the panel load to the MezzMaster. Once the load is transferred to the building and secured in place, the hydraulic clamps are released.

Structure

The MezzMaster has two header rails that have adjustable clamps to accommodate differing layouts of joists or beams. The header rails are designed with eight beam clamps (four/rail) to handle panels up to four joists or beams. Extensions to the header rails increase the capacity to ten clamps (five/rail) to handle panels up to five joists or beams. Extensions are used for larger panels provided they are not over 20,000 lbs.

Functions

The MezzMaster can rotate a panel sideways so that it can fit between building columns. A telehandler can tilt the panel forward and backward. The MezzMaster also has swivel functions for placing the panel in the building. The terms InnovaTech uses to describe functions are as follows:

- a. Rotation (Roll) controlled through MezzMaster roll cylinders
- b. Tilt (Pitch) controlled through telehandler knuckle
- c. Swivel (Pivot) controlled through MezzMaster turntable

The MezzMaster uses a telehandler carriage adapter that positions the attachment above the knuckle of the telehandler. The MezzMaster stows on a stow stand and is transported in a cradle that is part of the MezzJack transport system.

Nomenclatures

A. Clamp Assembly

- a. Clamp Jaw
- b. Clamp Wear Plate
- c. Hydraulic Cylinder
- d. Hydraulic Pressure Sensor
- e. Positioning Bolt

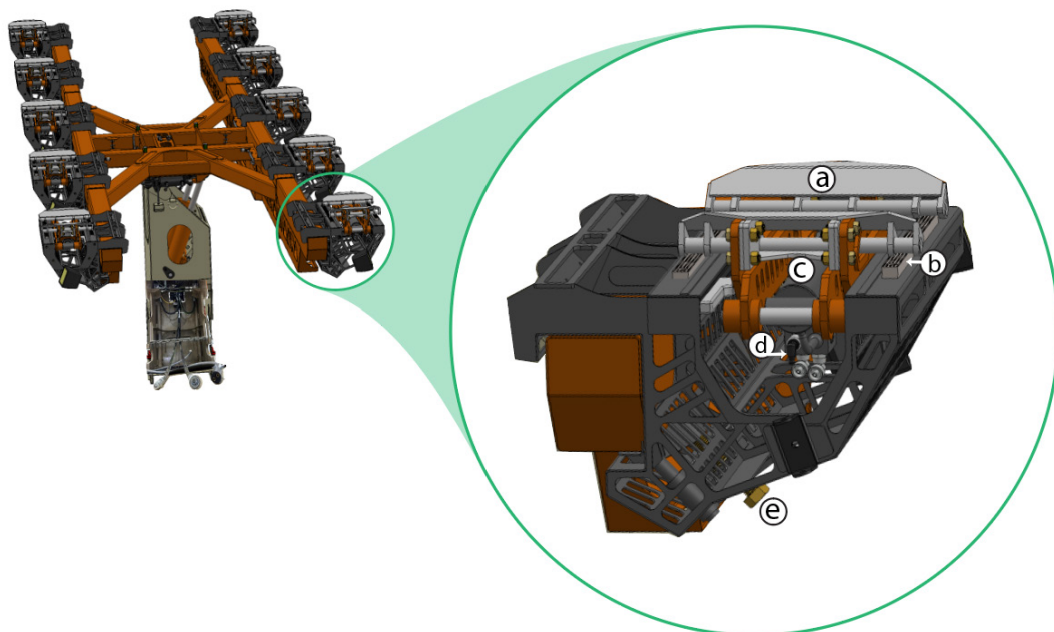

B. MezzMaster

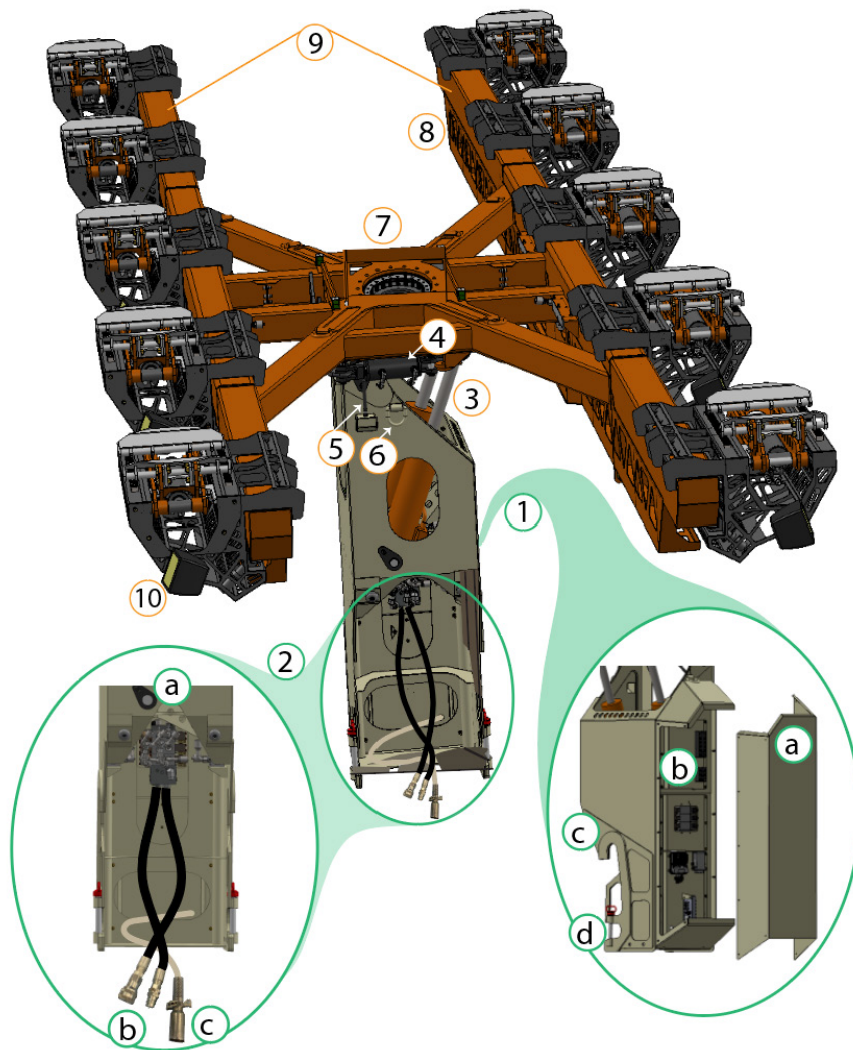

- | | |
|---|---|
| <ul style="list-style-type: none"> 1. Knuckle Base (Electrical Side) <ul style="list-style-type: none"> a. Electronics Cover b. Electrical Center c. D-Carriage Coupler d. Lock Pins (qty 2) 2. Knuckle Base (Hydraulic Side) <ul style="list-style-type: none"> a. Hydraulic Valve Junction b. Hydraulic Quick Connects to telehandler c. Electrical Plug to telehandler 3. Hydraulic Roll Cylinders | <ul style="list-style-type: none"> 4. Pivot Cylinders (qty 2) 5. Wireless Control Antenna 6. D Rings (Hoist/Lift Points) (qty 2) 7. Turn Table 8. Hose and Wire Gutters (2) 9. Header Rails 10. Lights |
|---|---|



3. Operation

3.1 Operation Safety

Keep work areas clean and tidy to prevent accidents. Use good judgment. Make sure the MezzMaster 200 will not be damaged by any procedure you choose.

3.2 Telehandler Up-Fit Kit

The MezzMaster comes with operation and radio-link components to be installed in the telehandler to which it is connected. The up-fit kit adds an advanced joystick for proportional hydraulic control, a power connection, and a transmitter that allows the MezzMaster to be paired to a telehandler wirelessly.

Each transmitter must be kept with the MezzMaster that it is paired with. For this reason, InnovaTech attaches magnets to each transmitter. Before operating a MezzMaster take the transmitter off the MezzMaster and plug it into the computer within the telehandler cab. **The operator is responsible for putting the transmitter back on the MezzMaster before it is transported away from a jobsite.**

3.3 Set-up



1. Attach clamps to header rail of MezzMaster according to beam or joist layout.
2. Adjust tightening bolts until clamps are secure. **Clamps on each rail must align with those on opposite rail.** (See Safety 1:4)
3. Hook up clamp hydraulic hoses.
4. Make sure hose and wire pins are secured over hose and wire gutter.
5. Connect MezzMaster to telehandler.
6. Connect hydraulic hoses and power supply.
7. Remove magnet-mounted transmitter from MezzMaster and plug it into the controller behind telehandler seat.
 - a. When transmitter is connected, the sensor light is green.
 - b. When transmitter is disconnected, the sensor light is red.

3.4 Inspection

Per Shift:

Ensure:

- clamp securing bolts are tight.
- turntable bolts are tight.
- hydraulic hoses and cylinders have no leaks.
- frame has no dents.
- welds and frame members have no cracks.
- wiring has no loose or broken connections.
- prox sensor is clear.
- extension connection bolts are tight.
- extension connection seam has no bows or dents more than 1/8 in. at header rail seams.

Up-fit Kit for D Carriage Telehandler		
Advanced Joystick Controls	Hydraulic Quick Connects and Electric Outlet	Computer and Wireless Transmitter
		
In Cab	In Boom	Behind Cab Seat
<p>NOTICE PORTABLE TRANSMITTER!</p> <p><i>It is important that the transmitter stay with the MezzMaster that it is paired with. Make sure it is not left in the telehandler when its MezzMaster leaves a job site.</i></p>		





 **USE LOCK-OUT/TAG-OUT!**

If the MezzMaster does not pass inspection, lock and tag it "Out of Service" until the problem is corrected.

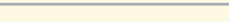

3.5 MezzMaster Controls

A. Telehandler 2450 Joystick

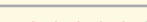
LED Light Patterns	
Solid Green 	Fully Clamped
Solid Red 	Unclamp Finished
Alternating Red/Green 	Clamp/Unclamp Transition
Slow Flash Red, Solid Green 	Unclamp Allowed
Fast Flash Red, Solid Green 	Unclamp Attempt Rejected
Flashing Red and Flashing Green 	Start-Up in a Disallowed State

MezzMaster Mode

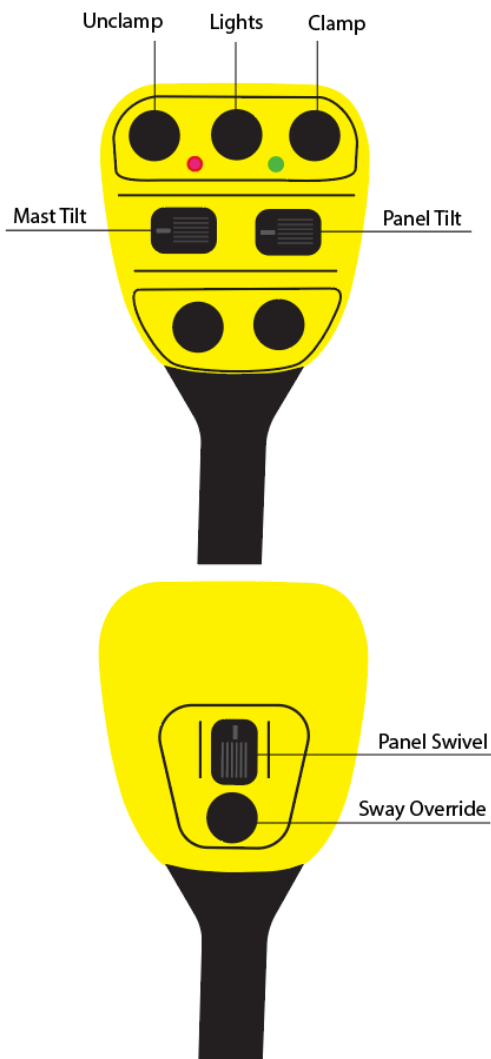

Swing Carriage Mode

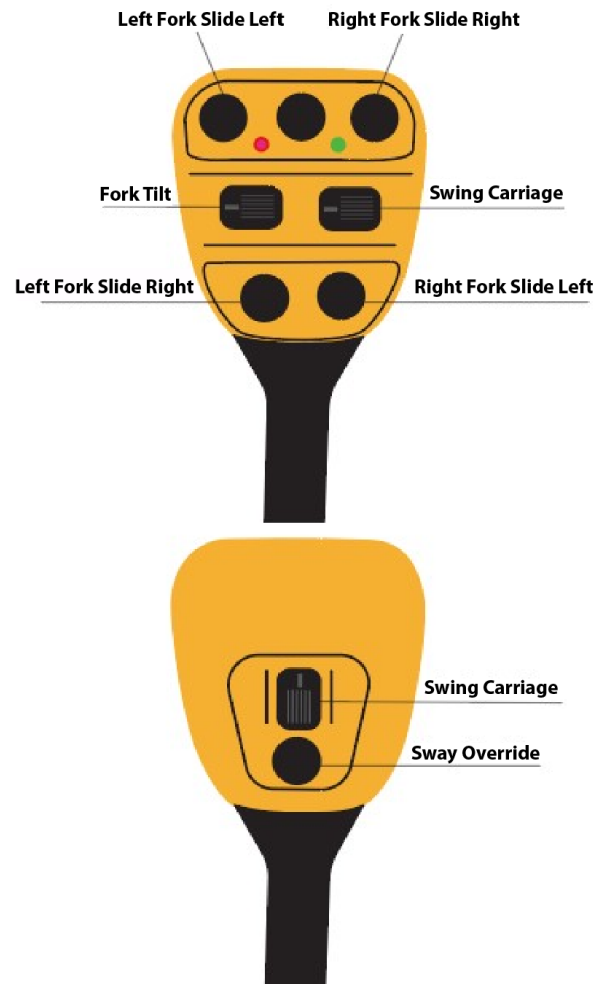

B. XTreme XR-50100 Joystick (Trackzilla)

Trackzilla Mode

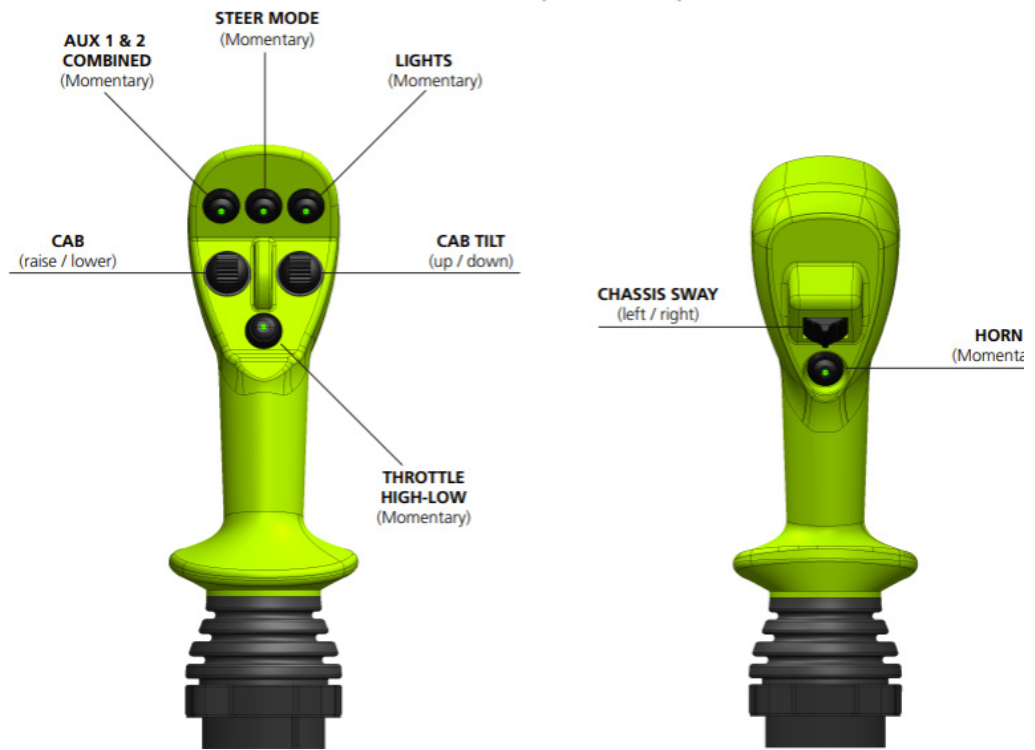

Swing Carriage Mode

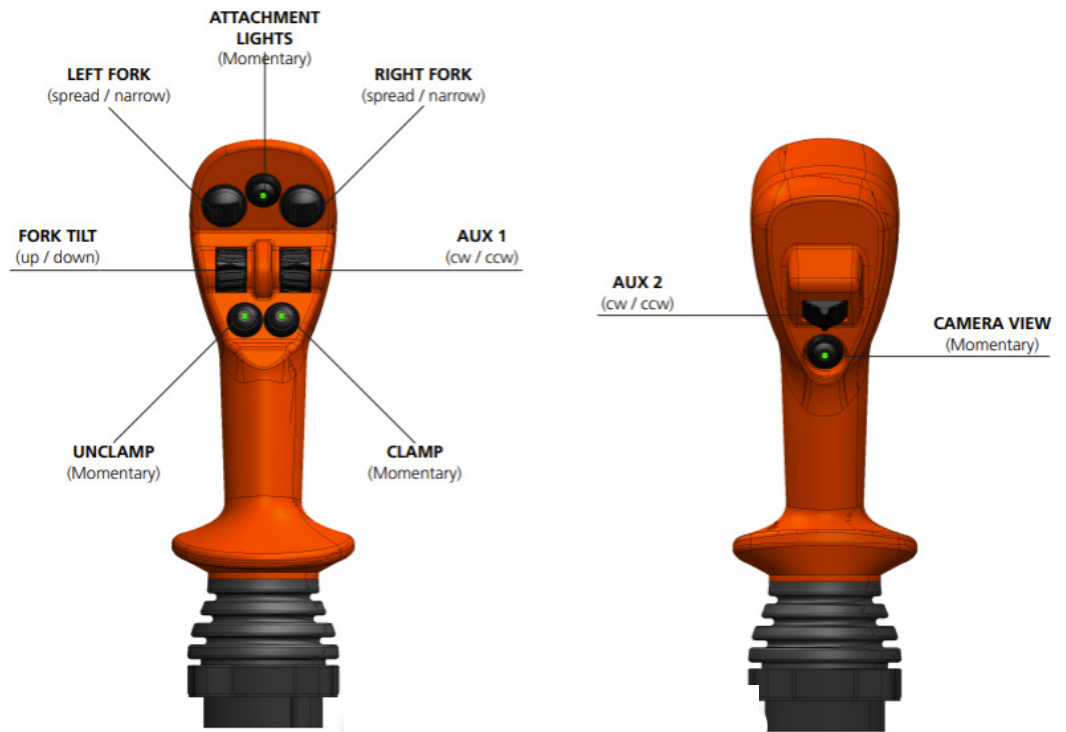

3.6 Operating MezzMaster

1. Drive the Mezzmaster under a prefabricated section of wall or mezzanine.
2. Align MezzMaster Clamps with beams or joists.
3. Before engaging the clamps ensure beams or joists are properly positioned.
4. Use the clamp button on the joystick to engage the clamps.
5. Lift and transport the prefabricated section to the proper place for placement and attachment.
6. Once the prefabricated section is properly secured to the building, use the "Unclamp" button on the joystick to release it.
7. Before lowering the Mezzmaster, ensure all clamps are released.

3.7 Transport, Storage

1. Attach extensions before transporting.
2. Hoist the MezzMaster onto the MezzJack Trailer.
3. Lower the MezzMaster ensuring the knuckle goes down into the knuckle cradle. Set it closer to the front within the cradle to ensure knuckle goes all the way to the floor of the trailer.
4. Use ratchet straps to secure the clamps to the MZM frame.
5. Secure the MZM to the MezzJack pocket rail using the Rotation Restraints.
6. Bolt Rotation Restraints to Pocket Rail of MezzJack Trailer. (*Rotation Restraints circled blue.*)

Refer to MezzJack manual for detailed description of MezzJack trailer.

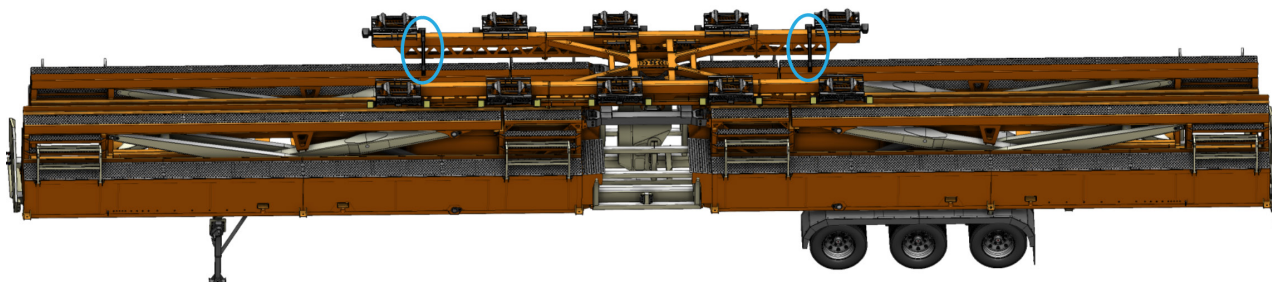

4. Maintenance

per shift:

- Apply grease to zerks at ends of each hydraulic cylinder.
- Apply grease to zerk on turntable.

6 Month Inspection

- Thoroughly inspect MezzMaster for excessive wear or corrosion that would affect safe function.
- Thoroughly inspect each clamp for excessive wear or corrosion that would affect safe function.
- Inspect for worn or missing markings on controls.
- Inspect for missing or illegible labels and decals.

A Mezzmaster that has been idle for one month to a year shall be inspected by the monthly inspection guidelines.

MezzMaster must be inspected:

- For constant or intermittent use at one locality, once every 6 months.
- Immediately before and immediately after it has been subjected to abnormal load or shock.



USE LOCK-OUT/TAG-OUT!

If there is any question or doubt about the safe use of a MezzMaster, tag it "Out of Service" until it can be inspected by authorized personnel.



5. Specifications

General

Telehandler Compatibility:

XR-2450 D Carriage
XR 50100 with G-D Carriage Adapter

Dimensions

with extensions
Length 27 ft. 11.75 in
Width 8 ft. 3 in.
Height 8 ft.

without extensions
Length 12 ft. 2 in.
Width 8 ft. 3 in.
Height 8 ft.

Total Weight 6,200 lbs
without extensions (including 4 inner clamps) 3,740 lbs
weight of individual clamps 230 lbs

Capacity

without extensions 21,000 lbs
with extensions 19,200 lbs

Maneuverability

Rotation (Roll) *MezzMaster*
.....2° counterclockwise/45° clockwise
Tilt (Pitch) *Telehandler*
(may vary) 29° Back/64° Forward
Swivel (Pivot) *MezzMaster*
.....35° counterclockwise/35° clockwise

Systems

Electrical System

(powered by Xtreme 7038)







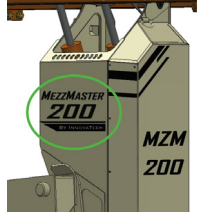

Voltage 12 V
Amperage 40 Amp

Hydraulic System

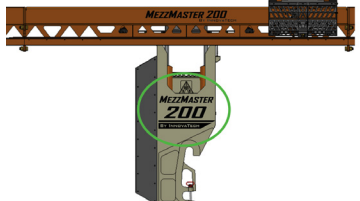
Max Pressure 3,200 psi
Normal Pressure 2,800 psi
System Capacity 12 gallon
Hose Burst Strength 12,000 psi
Ambient Temperature Range 0 to 120°F
Hydraulic Fluid Recommended AW46

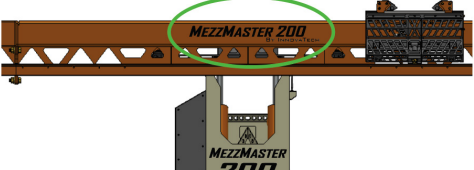

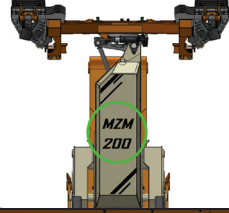
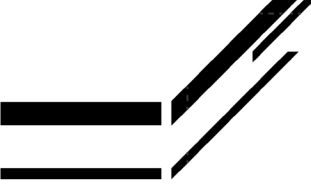
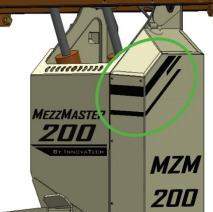



Appendix: Labels and Decals

Decal and Label Chart			
Decal ID	Qty	Decal Visual	Decal Application
INN-MZM200-LM04-V01	1		
INN-MZM200-LM03-V01	1		
INN-MZM200-LM02-V01	2		
INN-MZM200-LM01-V01	1		
INN-MZM200-DL01-V01	1		
INN-MZM200-DL02-V01	1		

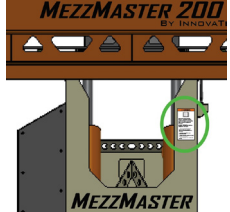

MezzMaster 200

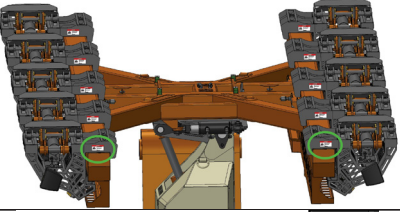
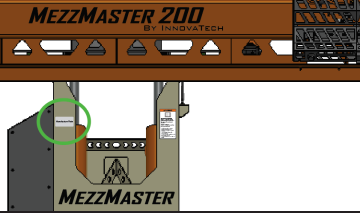
<p>INN-MZM200-SM01-V01</p>	<p>1</p>	<div style="border: 1px solid black; padding: 5px;"> <p style="text-align: center;">WARNING</p>  <p>IMPROPER USE HAZARD DEATH or SERIOUS INJURY could result from not following flow for operate equipment properly.</p> <p>DO NOT OPERATE or work on equipment until you:</p> <ul style="list-style-type: none"> • Read and understand equipment manual, safety labels, register with state, and applicable government regulations. • Are trained and qualified to safe equipment operation. • Consult Innovatech to update any printed instructions and manuals. • Consult Innovatech LLC to replace lost manuals. </div>																																																																																									
<p>INN-MZM200-SM02-V01</p>	<p>1</p>	<div style="border: 1px solid black; padding: 5px;"> <p style="text-align: center;">WARNING</p>  <p>INJECTION HAZARD</p> <p>DEATH or SERIOUS INJURY could result from contact with pressurized fluid.</p> <p>KEEP CLEAR of leaks.</p> </div>																																																																																									
<p>INN-MZM200-SM03-V01</p>	<p>20</p>	<div style="border: 1px solid black; padding: 5px;"> <p style="text-align: center;">DANGER</p>  <p>PINCH POINT HAZARD</p> <p>DEATH or SERIOUS INJURY will result from contact with pinch points.</p> <p>KEEP CLEAR</p> </div>																																																																																									
<table border="1" style="width: 100%; border-collapse: collapse;"> <thead> <tr> <th colspan="4" style="text-align: left; color: #0070C0;">MezzMaster 200</th> </tr> <tr> <th colspan="4" style="font-size: 8px;">MEZZMASTER 200 SPECIFICATIONS</th> </tr> <tr> <th>SERIAL</th> <th>MODEL</th> <th>YEAR</th> <th>VERSION</th> </tr> </thead> <tbody> <tr> <td>INN-MZM200V01-5-2309287</td> <td>INN-MZM200</td> <td>2023</td> <td></td> </tr> <tr> <th colspan="4" style="font-size: 8px;">EQUIPMENT SPECIFICATIONS</th> </tr> <tr> <td>with EXTENSIONS</td> <td>without EXTENSIONS</td> <td colspan="2"></td> </tr> <tr> <td>LENGTH</td> <td>165 in</td> <td>355 in</td> <td></td> </tr> <tr> <td>WIDTH</td> <td>99 in</td> <td>99 in</td> <td></td> </tr> <tr> <td>HEIGHT</td> <td>95 in</td> <td>95 in</td> <td></td> </tr> <tr> <td>WEIGHT (empty)</td> <td>3,740 lbs</td> <td>6,200 lbs</td> <td></td> </tr> <tr> <td>CAPACITY (lbs)</td> <td>11,000 lbs</td> <td>19,200 lbs</td> <td></td> </tr> <tr> <td>Fore-to-Aft Capacity</td> <td>128 in</td> <td>518 in</td> <td></td> </tr> <tr> <td>CLAMP QTY</td> <td>4 (2/218in)</td> <td>10 (5/218in)</td> <td></td> </tr> <tr> <th colspan="4" style="font-size: 8px;">CLAMP SPECIFICATIONS</th> </tr> <tr> <td>MAX CLAMP OPENING</td> <td colspan="3">34 in</td> </tr> <tr> <td>CAPACITY/A</td> <td>5,250 lbs</td> <td>WEIGHT/EA</td> <td>230 lbs</td> </tr> <tr> <th colspan="4" style="font-size: 8px;">PNEUMATIC SPECIFICATIONS</th> </tr> <tr> <td>AMBIENT TEMP RANGE</td> <td colspan="3">10-120 °F</td> </tr> <tr> <td>MAX WVD. PRESSURE</td> <td colspan="3">1,200 psi</td> </tr> <tr> <td>OPER. VOLTAGE RANGE</td> <td colspan="3">11-15</td> </tr> <tr> <td>NORMA. OP. PRESSURE</td> <td colspan="3">1,200 psi</td> </tr> <tr> <td colspan="4" style="font-size: 8px;">Made in USA</td> </tr> </tbody> </table>	MezzMaster 200				MEZZMASTER 200 SPECIFICATIONS				SERIAL	MODEL	YEAR	VERSION	INN-MZM200V01-5-2309287	INN-MZM200	2023		EQUIPMENT SPECIFICATIONS				with EXTENSIONS	without EXTENSIONS			LENGTH	165 in	355 in		WIDTH	99 in	99 in		HEIGHT	95 in	95 in		WEIGHT (empty)	3,740 lbs	6,200 lbs		CAPACITY (lbs)	11,000 lbs	19,200 lbs		Fore-to-Aft Capacity	128 in	518 in		CLAMP QTY	4 (2/218in)	10 (5/218in)		CLAMP SPECIFICATIONS				MAX CLAMP OPENING	34 in			CAPACITY/A	5,250 lbs	WEIGHT/EA	230 lbs	PNEUMATIC SPECIFICATIONS				AMBIENT TEMP RANGE	10-120 °F			MAX WVD. PRESSURE	1,200 psi			OPER. VOLTAGE RANGE	11-15			NORMA. OP. PRESSURE	1,200 psi			Made in USA				<p>1</p>		
MezzMaster 200																																																																																											
MEZZMASTER 200 SPECIFICATIONS																																																																																											
SERIAL	MODEL	YEAR	VERSION																																																																																								
INN-MZM200V01-5-2309287	INN-MZM200	2023																																																																																									
EQUIPMENT SPECIFICATIONS																																																																																											
with EXTENSIONS	without EXTENSIONS																																																																																										
LENGTH	165 in	355 in																																																																																									
WIDTH	99 in	99 in																																																																																									
HEIGHT	95 in	95 in																																																																																									
WEIGHT (empty)	3,740 lbs	6,200 lbs																																																																																									
CAPACITY (lbs)	11,000 lbs	19,200 lbs																																																																																									
Fore-to-Aft Capacity	128 in	518 in																																																																																									
CLAMP QTY	4 (2/218in)	10 (5/218in)																																																																																									
CLAMP SPECIFICATIONS																																																																																											
MAX CLAMP OPENING	34 in																																																																																										
CAPACITY/A	5,250 lbs	WEIGHT/EA	230 lbs																																																																																								
PNEUMATIC SPECIFICATIONS																																																																																											
AMBIENT TEMP RANGE	10-120 °F																																																																																										
MAX WVD. PRESSURE	1,200 psi																																																																																										
OPER. VOLTAGE RANGE	11-15																																																																																										
NORMA. OP. PRESSURE	1,200 psi																																																																																										
Made in USA																																																																																											





Innovatech Manufacturing
4360 N WECCO Rd
Cedar City, UT 84721
<https://support.innova.tech>

