

InnovaTech Panelization Table

EQUIPMENT SAFETY, OPERATION, AND MAINTENANCE

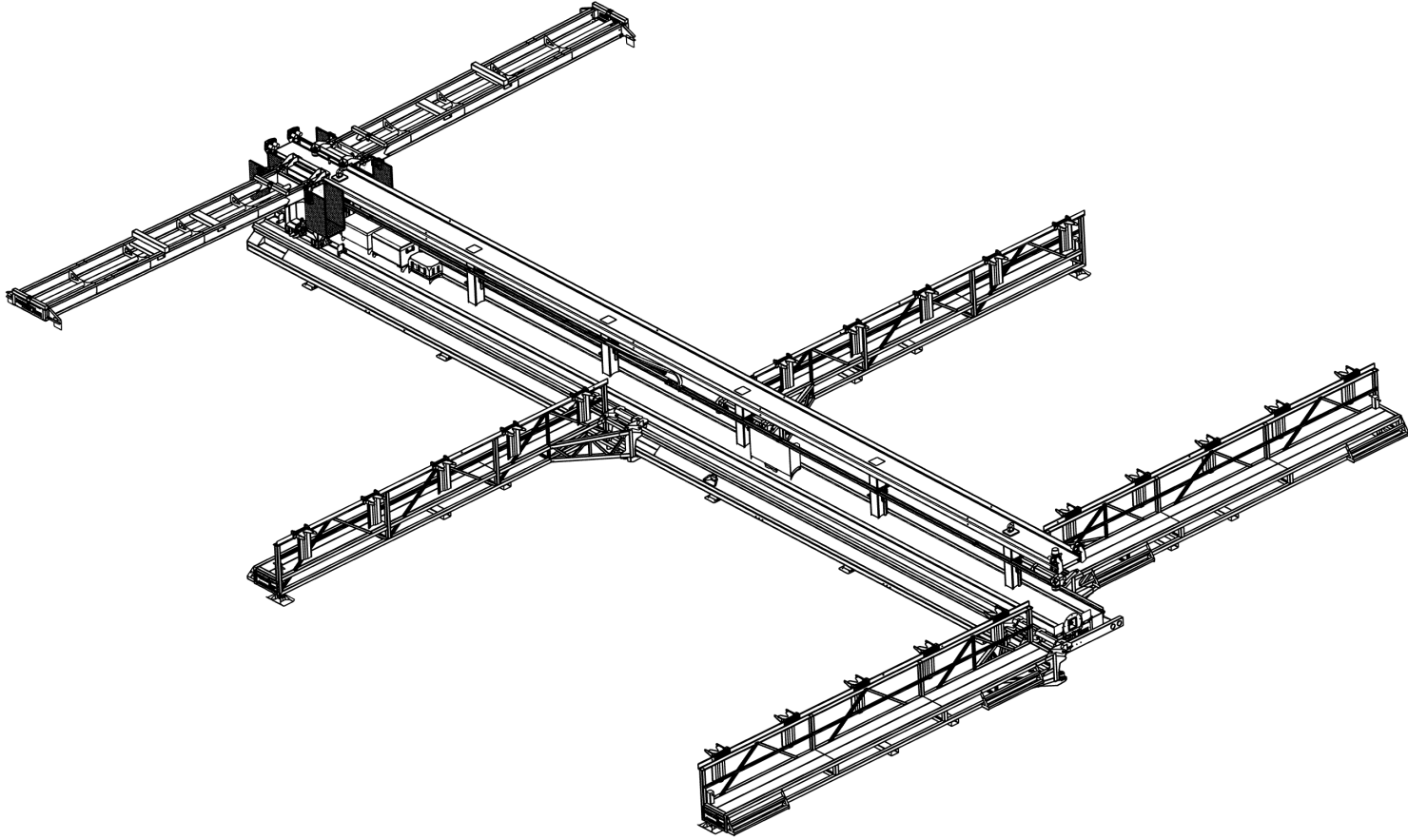

Panelization Table | PT-600

INNOVATECH, LLC | HC 65 PO BOX 218 | KANARRAVILLE, UT 84742

PT6-MNLR01

Contents

Document Info	ii		
InnovaTech Panelization System	1		
Overview	1		
PT-600 Panelization Table	1		
Safety	2		
Pre-Task Safety Analysis	2		
Operator Responsibility	4		
Operator Qualifications	4		
Personal Protection Equipment (PPE)	5		
Pre-Operation Inspection Checklist	5		
Safety Markers	6		
Modifications	7		
Mounting/Dismounting	7		
Worksite Safety	7		
Maintenance, Service, & Repair	8		
Lockout/Tagout (LOTO)	9		
Emergency Stop (E-Stop)	9		
Support Equipment	9		
Nomenclature	10		
General	10		
Main Frame	11		
Catwalk	12		
Gantry	13		
Specifications	14		
Mobilization	14		
		Receiving	14
		<i>Lifting Device</i>	14
		<i>Rigging</i>	14
		<i>Insurance</i>	14
		Assembly	15
		Site Requirements	15
		Operating Conditions	15
		Fuel Requirements	15
		Operation	15
		<i>Personnel Requirements</i>	15
		Material Handling	16
		Operation	16
		Maintenance	16
		Contact Us	16

Document Info

This document contains subject matter to which InnovaTech, LLC, has proprietary rights. Recipients of this document shall not duplicate, use, or disclose information contained herein, in whole or in part, for any use other than the purpose for which this manual was provided.

InnovaTech, LLC, believes the information described in this manual is accurate and reliable. From time to time, design improvements will be made to the InnovaTech Panelization Table. Photographs, text, and sketches within the body of this manual may not exactly represent your equipment. In general, this manual contains the most up-to-date information available. However, InnovaTech, LLC, cannot accept any responsibility, financial or otherwise, for any consequences arising out of the use of this material. The information contained herein is subject to change, and revisions may be issued to advise of such changes or additions.

InnovaTech, LLC, strives to continually improve their user documentation. If you have any questions or concerns about the content of this service and maintenance guide, we want to hear from you. Please e-mail us at support@innovatechservice.com or contact us by mail at:

INNOVATECH, LLC
TECHNICAL PUBLICATIONS
HC 65 PO BOX 218
KANARRAVILLE, UT, USA 84742

InnovaTech, LLC, is continually improving their equipment to bring you the latest in building system technology. For that reason, your InnovaTech Panelization Table may differ slightly from what is described in this document. If you have any questions, please contact us at support@innovatechservice.com.

The InnovaTech, LLC, Panelization System is under US PATENT PENDING protection.

©2021 InnovaTech, LLC. All Rights Reserved.

InnovaTech Panelization System

Overview

The InnovaTech Panelization System is an industrial equipment solution designed to work in conjunction with other common construction equipment to create a safe and efficient workplace for employees involved in the erection of steel structures.

The key piece of equipment involved in the InnovaTech Panelization System is the PT-600 Panelization Table. This equipment is paired with standard material handling equipment such as extendable boom forklifts, and cranes, as well as welding equipment strategically positioned to streamline the assembly of open web steel joists into building panelized modules; utilizing assembly line principles and vastly improving worker safety and efficiency.

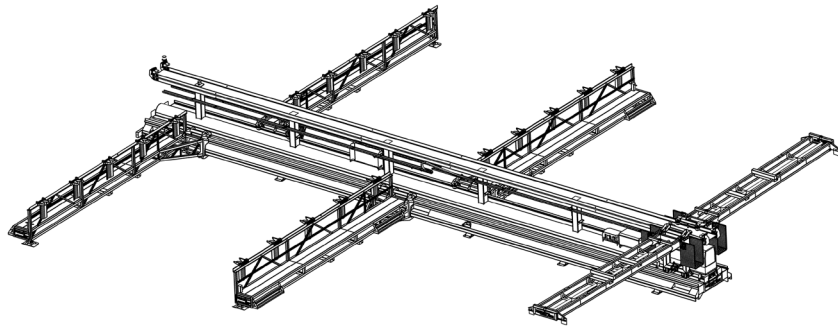

Fig. 1: Deployed Mode

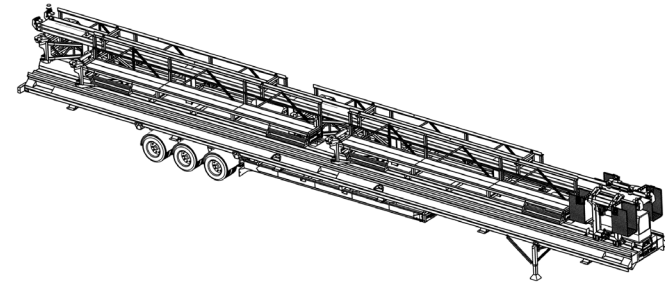

Fig. 2: Stow Mode

PT-600 Panelization Table

The Panelization Table is specifically designed to template pre-manufactured open web steel roof joists for assembly into panelized modules at the job site. The panelized modules are to be lifted by crane or Mezzmaster to the final installation point in the structure. This equipment enables workers to assemble the roof and mezzanine components onsite and at ground level in an accurate and safe manner, while reducing the potential safety risks common to steel erection.

The PT-600 can be disassembled and its sub-structures conveniently fitted onto the main frame for stowage.

The equipment is mirror duplicated on each of its two sides, allowing a roof section to be arranged and assembled, while another section on the opposite side is being prepared for lifting and final positioning into the building structure, creating a safe and efficient work environment.

The PT-600 equipment is constructed of a large open upright frame at a length scaled to the largest length of open web joists manufactured by steel component suppliers. Catwalk pairs are positioned perpendicularly along the main frame to accommodate the joist matrix between the catwalks. The distance between the catwalk pairs is determined by the length of open web steel joists that are being utilized. The catwalk rails facilitate the positioning of specialized adjustable brackets that allow the joist groups to be positioned according to the matrix described in the building structure blueprints.

Weld connections are made using a central power source mounted on the main frame with electrical leads powering a welder wire feeder which is attached on a rotating post in the center of the joist matrix. Attached to the post is an articulating arm which carries the welder feeder whip and welder gun above the outrigger beams. This enables the worker to step among the outrigger beams underneath the joist matrix and pull the weld equipment around to reach to the farthest extents of the joist matrix to enable the worker to make the welded connections un-hindered, at ground level.

Once the joists have been positioned in the template matrix, and have had their purlins mounted and welded, a cantilevered rolling gantry travels along the equipment main frame bearing a bunk of corrugated steel sheathing. As the gantry slowly travels, each sheet is shifted into place by workers onto the platform which was created by the matrix of steel joists. The steel sheathing is then attached to the joist with powder actuated fasteners and prepared for lifting with specialized rigging engineered for the proper load distribution of the resulting panelized module.

In conjunction with the process of lifting and placing of the large panelized roof module, the final step is to weld-stitch the joints of the building joists together to form the complete roof structure of the building.

Safety

This equipment was specifically designed to enhance safety in the steel construction work environment. InnovaTech endeavors to maintain a positive reputation in the industry by preventing accidents and creating a safe, efficient, and productive work environment.

Pre-Task Safety Analysis

Although the PT-600 enhances safety, it remains important for workers to carefully analyze the work to be performed. Identifying work methods, planning actions, communicating clearly, maintaining a positive attitude, teamwork, and compliance to worksite authority, all contribute to a safe worksite.

Use of the PT-600 should be included in a steel erection pre-task safety analysis at the beginning of each shift. Some topics to consider during pre-task safety analysis may include weather conditions, site specific plans. This Equipment Operation and Maintenance Manual provides information needed to safely operate the PT-600. This manual should be considered an appurtenant part of the PT-600, and kept in the protective enclosure located with the PT-600.

Notice

This Safety, Equipment Operation and Maintenance Manual provides information needed to safely operate the PT-600. This manual should be considered an appurtenant part of the PT-600, and kept in the protective enclosure located on the panel table.

Before operating the PT-600, read this operators manual completely and carefully to understand the safety instructions and the operation of controls and safety equipment. You must comply with all DANGER, WARNING, and CAUTION notices. Refer to the Safety Markers section for detailed information on safety marker definitions.

InnovaTech Products reserves the right to make technical changes to our product for product improvement and customer satisfaction. This manual may contain illustrations and photographs (for demonstration purposes), which slightly deviate from the actual product.

Safety information provided in this manual is a basic guide to help improve safety and prevent accidents. InnovaTech Products cannot foresee every circumstance that might involve a potential hazard. Warnings in this manual and on the PT-600 do not encompass all potential safety hazards. You are responsible for safe

operation of the Panelization System and all attachments. You must satisfy yourself that the techniques, operating procedures, work methods, and systems are safe and will work for your situation.

The safety of everyone around the for PT-600 depends significantly on your knowledge and understanding of all correct and safe operating practices and procedures. You can help prevent accidents by remaining alert and recognizing potentially hazardous situations.

Follow State and Federal health and safety rules and/or local regulations for operating and maintaining the PT-600. This manual does not replace any laws and regulations. The operator is required to comply with all applicable laws and regulations.

Operator Responsibility

WARNING

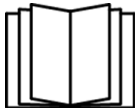

The Panelization System is potentially dangerous if proper safety procedures are not followed. Workers who operate, maintain, or work near the PT-600 can be at risk of run over incidents or can be crushed or caught by the PT-600 or its parts which could result in death or serious injury if the PT-600 is not properly operated or maintained.

Read the Operation and Safety Manual BEFORE operating the PT-600. Follow all safety instructions and labels. Only operate the PT-600 if you understand the safety instructions and warnings in all applicable manuals and technical publications. Always follow all State and Federal health and safety laws and/or local regulations. You must have the required training, skills, and tools to perform installation, operation, maintenance, or repair procedures properly and safely. Make sure the PT-600 and attachments will not be damaged or made unsafe by any procedures you choose.

BEFORE starting the engine, do the following:

- Read the Operation and Safety Manual
- Read all the Safety Labels on the PT-600
- Clear all people out of the way of any moving parts

Educate yourself and practice safe use of the PT-600 controls in a safe, clear area, BEFORE you operate this PT-600 on a worksite.

It is your responsibility to observe applicable laws and regulations and to follow the manufacturer's instructions on the PT-600 operation and maintenance.

Operator Qualifications

All operators must be trained before operating the PT-600. Training standards must be approved by InnovaTech. Operators must operate the PT-600 according to ALL appropriate safety regulations. Operator trainees must remain under observation and supervision of an experienced operator. Operators must be in good physical and mental condition, with appropriate reflexes, reaction time, vision, depth perception, and hearing.

Operators must read this operators manual completely and carefully to understand the safety instructions and the operation of controls. A brief description of controls, indicators, and instruments are provided as a convenience for the operator. These descriptions DO NOT provide complete operation instructions, and should not be substituted for proper operator training.

Operators must understand and comply with all DANGER, WARNING, and CAUTION notices. (Refer to the Safety Markers section for detailed information on safety marker definitions.)

Operators must have the required training, skills, and tools to perform installation, operation, maintenance, or repair procedures properly and safely. The operator is responsible to operate and maintain the PT-600 (and attachments) according to manufacturer's instructions.

If any doubt or question arises about the correct or safe methods for operating the PT-600, operators must not proceed until obtaining expert assistance from a qualified person.

Personal Protection Equipment (PPE)

PPE should be utilized according to the type of work and environmental conditions a worker is exposed to. These items may include reflective vests, gloves, helmets, goggles, face shields, hearing protection, respiratory protection, and fall protection.

Pre-Operation Inspection Checklist

Perform a pre-operation inspection and functional tests at the beginning of each work shift. Perform the pre-operation inspection first. DO NOT perform the pre-operation inspection with the engine running or hot. Contact with moving or heated parts could cause death or serious injury.

- Perform the pre-operation inspection and functional tests in an open area and away from any other obstacles or equipment. Inspections and functional tests may require assistance. Keep the assistant visible and a safe distance from the PT-600 to prevent death or serious injury.
- Become familiar with all safety and hazard labels, regulations, and procedures. Make sure all proper safety and hazard labels are attached to the PT-600 and remain legible.
- A brief description of controls, indicators, and instruments is provided as a convenience for the operator. These descriptions **DO NOT** provide complete operation instructions.
- Read and understand the entire manual to prevent death, serious injury, or equipment damage.
- Keep fingers and feet away from moving parts or pinch points to prevent pinching or crushing. **DO NOT** allow anyone between the tires and the PT-600 frame while operating the PT-600. Doing so can result in death or serious injury.

Walk around the ENTIRE PT-600 while visually performing the pre-operation inspection:

- Check that "Do Not Operate" tags have not been placed on the PT-600.
- Check that Operation and Safety Manual is in the protective case and legible.

- Check all hydraulic hoses and hose connections for wear or leaks.
- Check for loose or missing bolts and nuts.
- Check for bent flanges or any other damage to rims.
- Check electrical connections.
- Check hydraulic reservoir sight gauge for proper fluid level. Add hydraulic fluid, if necessary.
- Check for loose or damaged belts, hoses, and radiator fan blades.
- Check coolant reservoir level. Add radiator coolant, if necessary.
- Check engine oil level. Add engine oil, if necessary.
- Check electrical wires and connectors.
- Check cylinders and hydraulic lines for leaks or any other damage.
- Check battery terminals for corrosion.
- Check battery for cracked, melted, or damaged case.
- Check that all labels are present and legible. Replace any damaged or illegible labels.
- Check that personal belongings are secured in the personal storage box.

Safety Markers

Safety Markers are provided to remind the operator of hazardous situations. InnovaTech Products provides these symbols to help inform all operators, regardless of reading and language skills, of as many potential hazards as possible. These symbols cover many, but not all, potential dangers and hazards associated with operating the PT-600.

Make safety the priority while operating the PT-600. Learn and follow all safety messages in this manual and on PT-600 labels to prevent death, serious injury, or equipment damage.

The following pages include a list of some of the safety symbols that may be used on this PT-600.



This is the safety alert symbol. It is used to alert you to the potential personal injury hazards. Obey all safety messages that follow this symbol to avoid possible injury or death.

WARNING

INDICATES A POTENTIALLY HAZARDOUS SITUATION. IF NOT AVOIDED COULD RESULT IN SERIOUS INJURY OR DEATH. THIS DECAL WILL HAVE AN ORANGE BACKGROUND.

DANGER

INDICATES AN IMMINENTLY HAZARDOUS SITUATION. IF NOT AVOIDED, WILL RESULT IN SERIOUS INJURY OR DEATH. THIS DECAL WILL HAVE A RED BACKGROUND.

CAUTION

INDICATES A POTENTIALLY HAZARDOUS SITUATION. IF NOT AVOIDED, MAY RESULT IN MINOR OR MODERATE INJURY. IT MAY ALSO ALERT AGAINST UNSAFE PRACTICES. THIS DECAL WILL HAVE A YELLOW BACKGROUND.

Modifications

WARNING

Modifications to the PT-600 or attachments could affect table capacity and/or stability which could result in death or serious injury. DO NOT make modifications to the PT-600 or attachments without prior written approval from InnovaTech, LLC. Where such authorization is granted, capacity, operation, and maintenance instruction plates, tags, or labels shall be changed accordingly.

- Unauthorized modifications or alterations will void the warranty.
- **DO NOT** modify, disable, or bypass any safety devices.
- **DO NOT** burn or drill holes in attachments.

Mounting/Dismounting

WARNING

Failure to use proper safety procedures when mounting and dismounting the PT-600 could result in death or serious injury.

- Keep steps clear of dirt, mud, snow, ice, debris, and other hazards.
- Face the PT-600 for mounting.
- **DO NOT** use the controls as hand holds or steps. Avoid accidentally engaging or disengaging a control.

- **DO NOT** jump from the PT-600. Clothing can get caught. Landing on uneven surfaces could result in death or serious injury.

Worksite Safety

WARNING

Use proper safety procedures and avoid hazardous situations while operating the PT-600 to prevent death, serious injury, or property damage.

- Keep the work site clear of any hazards while operating the PT-600.
- Check the work surface for loose soil conditions and overhead power lines.
- Know about underground hazards.
- **DO NOT** allow bystanders in the work area.
- Know the rules for movement of people and the PT-600 on the work site.
- Follow work site signs and signals.
- Stop for poor visibility conditions, such as dust, smoke, fog, etc. Wait until visibility improves before continuing.
- Operate the PT-600 in an enclosed area only if there is a ventilation system capable of routing hazardous fumes outside. Engine exhaust contains products of combustion that could cause death or serious injury.
- **DO NOT** operate the PT-600 if you are using drugs, alcohol, or any medication that might impair your judgment or ability.
- You must be 18 years of age or older to operate the PT-600.

WARNING

Check warning indicators and gauges frequently during operation. If a warning indicator is illuminated or a gauge shows abnormal readings, stop the PT-600, follow proper shut down procedures. Follow proper lock-out/tag-out procedures. Tag the PT-600 with “Do Not Operate” tags, and have a qualified mechanic service or repair the PT-600 before placing it into service again. Ignoring warning indicators can result in death, serious injury, or property damage.

Maintenance, Service, & Repair

Follow the manufacturer’s instructions for proper maintenance to make sure the PT-600 continues to meet manufacturer’s specifications. Failure to properly maintain the PT-600 can result in improper performance, which could cause death, serious injury, or property damage.

- Attach “Do Not Operate” tags to the Ignition switch and gantry controls before beginning any service or maintenance.

- The “Do Not Operate” tags indicate the PT-600 should not be operated until all service or maintenance is completed.
- Make sure basic maintenance is completed and service problems are corrected. Keep two (2) legible “Do Not Operate” tags with the PT-600 at all times.
- **DO NOT** operate the PT-600 and attachments if they require repairs.
- Death or serious injury can result from operating the PT-600 before all repairs have been made and all proper maintenance is completed.

Lockout/Tagout (LOTO)

Prior to performing the repair procedures to the PT-600 and in addition to applying “Do Not Operate Tags”:

See table below for specific LOTO procedures per Panel Table model.

Model	General Lockout/Tagout Procedures
Panel Table 1	<ul style="list-style-type: none"> • Remove key (if removable) from engine control panel; apply tag. • Turn off main power disconnect at 480 V power panel; apply lock and tag. • Turn off all energy isolation switches; apply lock and tag.
Panel Table 2 & 3	<ul style="list-style-type: none"> • Turn off power generator; apply lock and tag.
Panel Table 4 & 5	<ul style="list-style-type: none"> • Turn off power generator; apply lock and tag. • Turn off hydraulic pump; apply lock and tag.
Panel Table 6	<ul style="list-style-type: none"> • Turn off welder; apply lock and tag

Emergency Stop (E-Stop)

Emergency stops are located on each manbasket, and on both ends of main frame. Each stop module has a light for indicating whether any E-Stop is pressed or not.

- If no E-Stop is pressed, all lights are green.
- If one E-Stop is pressed, target E-Stop light turns red while all other E-Stop lights shut off.

Support Equipment

In conjunction with the Panelization System, workers should adhere to the safety requirements and the proper operation and maintenance of support equipment such as welders, fastening tools, lifting equipment, material handling equipment, etc., as well as maintaining a realistic understanding of your own physical strength and endurance.

Nomenclature

General

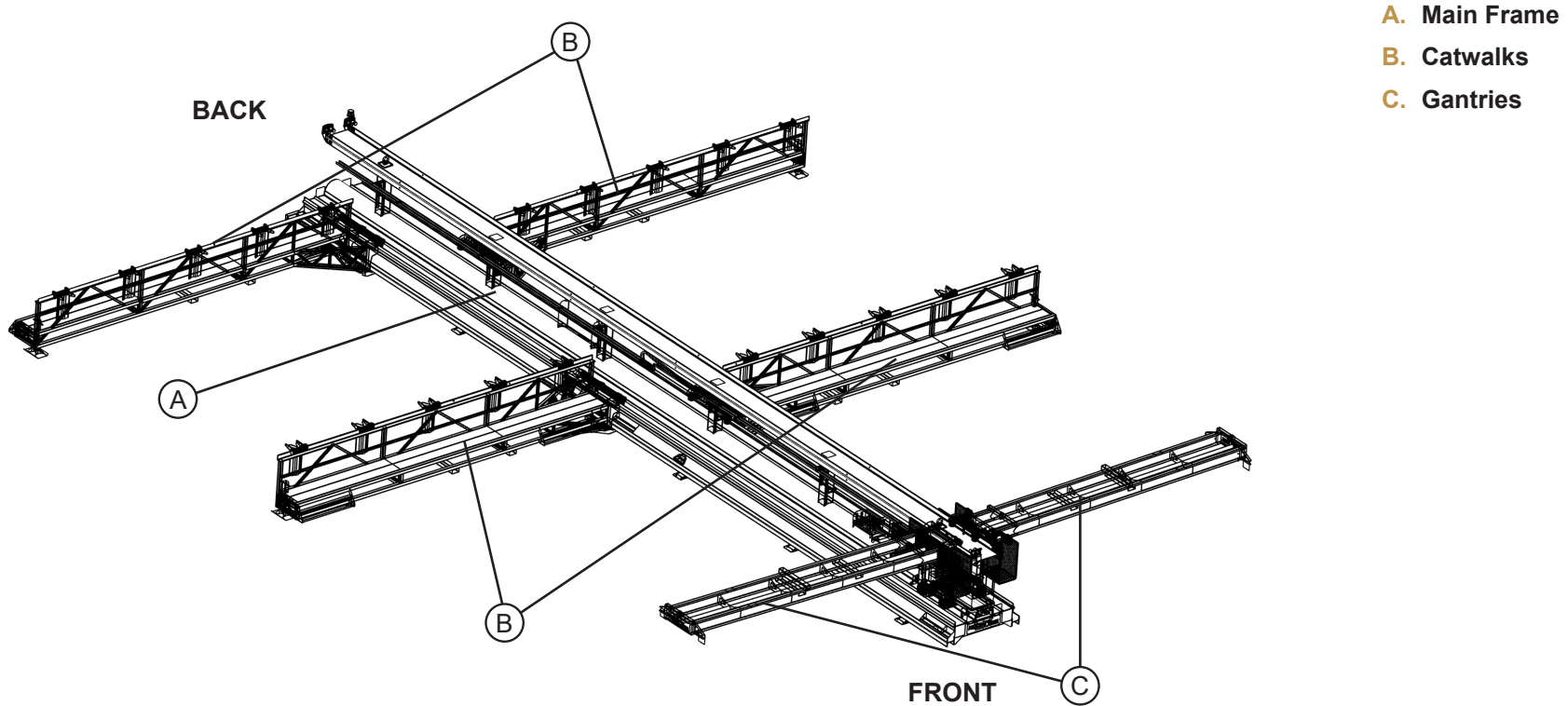

Main Frame

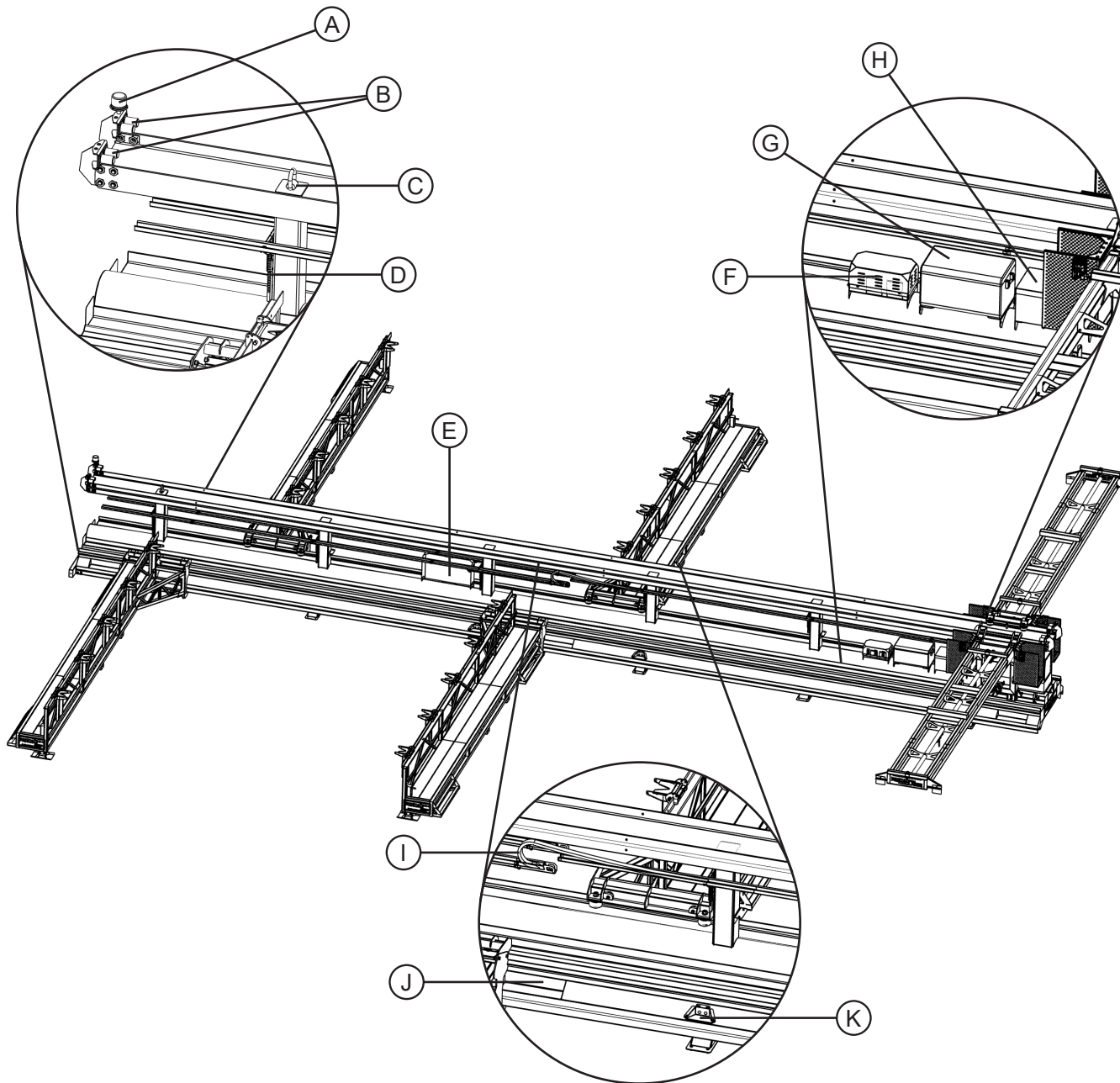

- A.** Beacon
- B.** Gantry Bumper Stops (on both ends of frame)
- C.** Lift Points (on both ends of frame)
- D.** Energy Chain Jack Stand
- E.** Electrical Panel
- F.** Welder
- G.** Fridge
- H.** Tool Box
- I.** Energy Chain
- J.** Catwalk Disconnection Point
- K.** Welder Connection Point

Catwalk

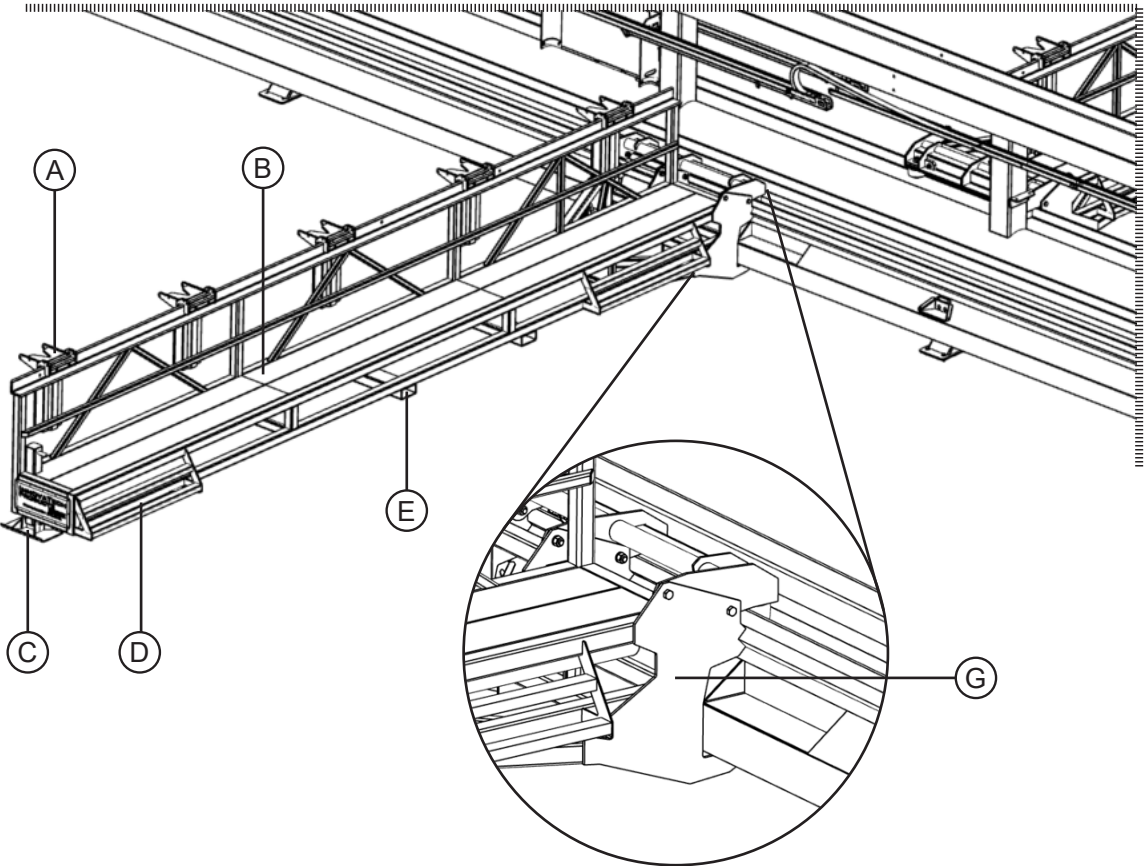

- A. Joist Pocket
- B. Catwalk Platform
- C. Jack Stand
- D. Step
- E. Forklift Pockets
- F. Catwalk Connection Joint

Gantry

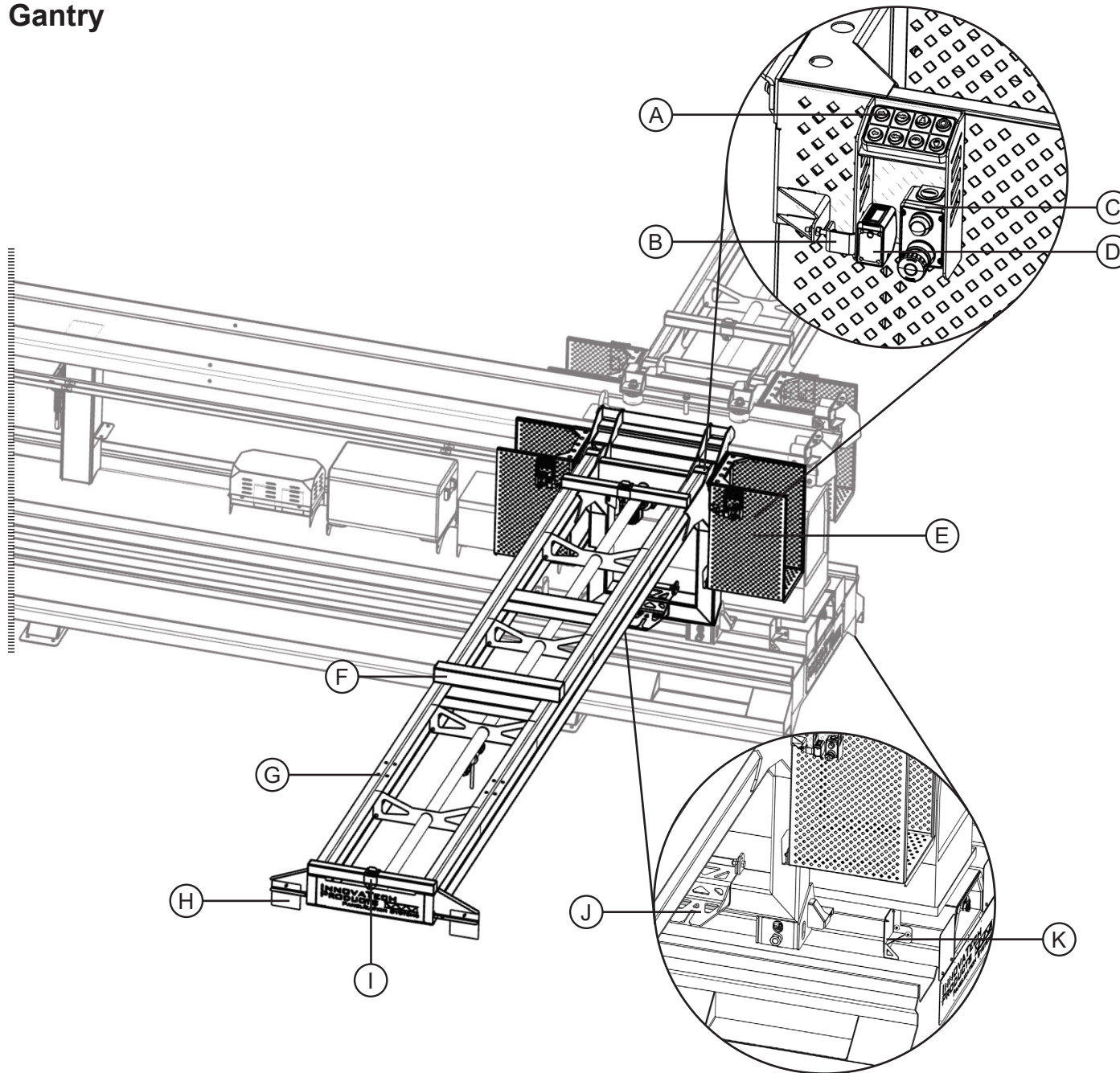

- A. Gantry Control Keypad
- B. Manual Adjustment Bracket for Sensor
- C. Emergency Stop
- D. Sensor Module
- E. Decking Bunk Support
- F. Bolt Holes for Stowage Mode
- G. Sensor Target
- H. Decking Catch
- I. Catwalk Travel Bracket
- J. Gantry Travel Stop

Specifications

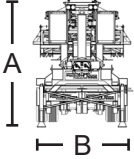
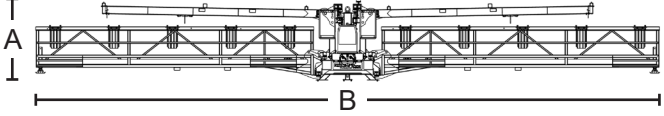
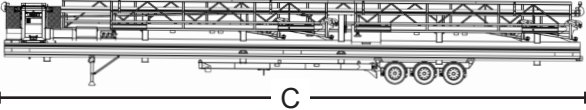
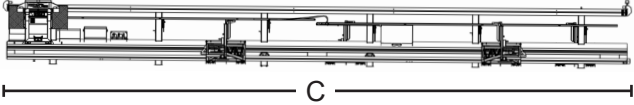
Description	Stowage Mode	Deployment Mode
Front View		
Side View		
Height	A. 11 ft. 7 in.	A. 8 ft. 9 in.
Width	B. 9 ft. 1.5 in.	B. 67 ft. 9 in.
Length	C. 80 ft. 11 in.	C. 80 ft. 11 in.
Weight		

Mobilization

Receiving

- Entrance onto the side should be accessible by tractor/trailer. Sufficient space for storage and access of separately transported components should be considered.
- The Diagram below illustrates the layout the overall size of the equipment in shipping configuration. Use this information to calculate the space requirements for equipment through roadways gates and structure sizes.

Lifting Device

- Ensure that the handling equipment utilized meets the load ratings necessary to accomplish the unloading and assembly of the machine. Utilize proper lifting points to avoid damage to the PT-600.

Rigging

- Experienced shipping and rigging professionals should handle the maximum load of the equipment.

Insurance

- Proper insurance coverage is advised.

Assembly

Site Requirements

The space necessary for assembly should allow for sufficient lift equipment access around the perimeter of the equipment. See figure to the right for assembled dimensions (overhead view).

Operating Conditions

- Concrete Surfaces – preferred surface for assembly and operation.
- Earth – capable of operating on prepared groundwork prior to building floor surface installation.
- Adverse weather conditions may limit operation. Remain in contact with official weather forecast information.

Fuel Requirements

- Type – Diesel
- Amount – 20gal

Operation

Personnel Requirements

The number of people needed for the efficient operation of the equipment is about 10. The job titles and functions are listed below.

- Forklift Operator - Material Handling
- Rigger, Signal and Spotter
- Crane Operator - Module Lifting and Placement
- Welder - Ground Assembly Work
- Assembly Worker – B-Deck Placement
- Assembly Worker – B-Deck Placement
- Assembly Worker – B-Deck Fastening

- Roof Worker – Module Placement
- Roof Worker – Module Placement
- Roof Welder – Truss Tie-In
- Roof Worker – B-Decking Finish

Material Handling

Storage of B-decking sheeting bunks can be placed in a nearby location for convenient access when replenishing supply needed for the moving gantries. Angle iron material for purlins and cross members can be store beneath the catwalk decking for easy access by the weld workman who is performing the groundwork. The actual open web steel roof joists should be delivered onsite and organized to facilitate proper layout of the building structure and allow easy forklift access for continuous assembly of the components.

Operation

Maintenance

Contact Us

INNOVATECH, LLC
HC 65 PO BOX 218 | KANARRAVILLE, UT 84742
Email support@innovatechservice.com

